

CONCORD 

4363z

4 MEGAPIXELS

User's Guide



• ENGLISH • FRANÇAIS • DEUTSCH • ESPAÑOL

www.concord-camera.com

CONCORD Eye-Q **4363z**

User's Guide



LANGUAGES

ENGLISH

FRANÇAIS

DEUTSCH

ESPAÑOL

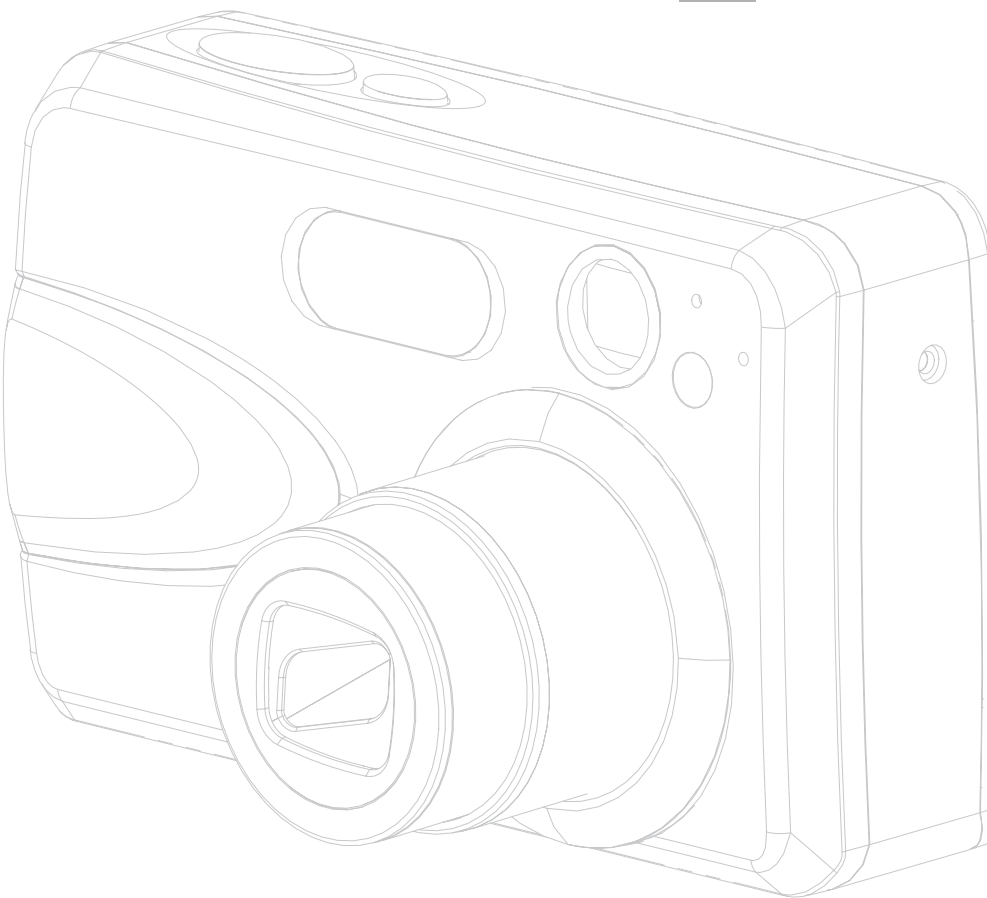

CONGRATULATIONS

Congratulations on the purchase of your new camera. Your camera has been carefully engineered and manufactured to give you dependable operation. Read this manual before operating the camera to become more familiar with it.

This manual has been written and formatted with depth and detail so that you can easily follow the instructions to maximize the features of your camera.

CAMERA OVERVIEW

Top/Front

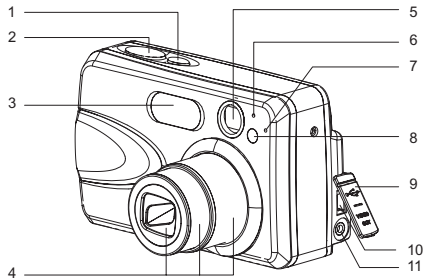

- | | |
|--------------------|---------------------------|
| 1. Power Button | 8. Red-eye Reduction LED/ |
| 2. Shutter Button | Self-Timer LED/ |
| 3. Flash | AF Assist Light |
| 4. Lens/ Lens Door | 9. Port Cover |
| 5. Viewfinder | 10. Mini-USB port |
| 6. Flash Sensor | 11. TV-Out port |
| 7. Microphone | |

- | | |
|-----------------------|------------------------|
| 12. Flash Ready LED | 24. Wrist Strap Holder |
| 13. Auto-Focus LED | 25. Move to right / |
| 14. Viewfinder | Macro () Button |
| 15. LCD | 26. Speaker |
| 16. LCD On/Off Button | 27. Move down / |
| 17. Tripod Socket | Self-timer () |
| 18. Battery/Memory | Button |
| Card Door | 28. Memory Card Slot |
| 19. Mode Switch | 29. Battery |
| 20. Thumbnail/Wide/ | Compartment |
| Tele Zoom Button | 30. Move to left / |
| 21. MENU Button | Continuous () |
| 22. Move up / | Shot Button |
| Flash () Button | 31. Reset Button |
| 23. OK Button | 32. Delete Button |

Bottom/Back

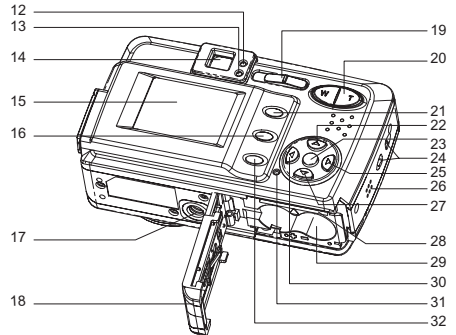

LCD ICONS

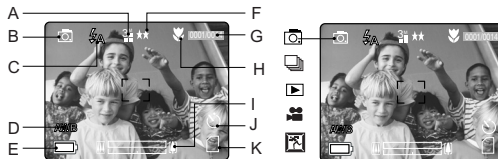

- | | | |
|----------------------------|------------------|-------------------|
| A. Resolution | G. Frame Counter | : Single Shot |
| B. Camera Mode | H. Macro | : Continuous Shot |
| C. Flash / Scene Selection | I. Zoom Bar | : Review |
| D. White Balance | J. Self-Timer | : Video Clips |
| E. Battery Level | K. Memory Card | : Sport |
| F. Image Quality | | |

Camera Features

- 4.0 Megapixels, 2272 x 1704 Resolution
- 1.5" Color LCD
- 3x Optical Zoom
- 6x Digital Zoom
- AVI Movie with Sound at 30fps
- 7 Preset Scenes
- Macro Mode
- Continuous Shooting Mode
- Self-timer
- Multi-area/Center-spot Auto Focus
- 16MB Internal Memory, SD Card Slot
- Compatible with Windows® 98/98SE/2000/ME/XP and Mac OS 9.0 or higher

TABLE OF CONTENTS

CAMERA OVERVIEW	2
Top/Front.....	2
Bottom/Back	2
LCD Icons.....	2
Camera Features.....	2
GETTING STARTED	5
Attaching the Wrist Strap.....	5
Loading the Batteries	5
Turning the Camera On and Off.....	5
Removing the Protective Plastic Film.....	5
Setting the Language, Date and Time.....	6
Checking the Battery Level	7
Turning the LCD On and Off	7
Internal memory / Inserting the Memory Card	8
Setting the camera's operational mode.....	9
TAKING A PICTURE	9
Taking Pictures with the viewfinder	9
Taking Pictures with the LCD	10
Using the Auto Focus Lock	11
Setting the Flash	12
Using the Optical Zoom.....	13
Using the Digital Zoom	13
Taking Pictures in Macro Mode.....	14
Taking Pictures in Continuous Mode	14
Taking Pictures in Self-timer Mode.....	15
Using the main menu in Camera mode	16
• Setting Capture mode.....	17
• Taking Pictures in Sport Mode.....	17
• Setting Image Quality	18
• Setting Image Resolution.....	18
• Selecting Scene Modes	20
• Setting White Balance	21
• Selecting Photo Effect	21
• Setting EV Compensation.....	22
• Setting ISO Sensitivity.....	23
• Setting Metering Method.....	24
• Setting AF Mode	24
TAKING VIDEO CLIPS	25
Taking Video Clips	25
Taking Video Clips in Self-timer Mode	26
Using the Main Menu in Video Clip Mode.....	26
Setting Video Resolution	27
REVIEWING YOUR FILES	28
Using Review Mode	28
Reviewing Pictures/Video Clips.....	28

Enlarging Stored Picture	29
Using Thumbnail View.....	30
Using the Delete Button	30
Using the main menu in Review Mode	32
• Deleting Files	33
• Using slide show.....	34
• Transferring Files from Internal Memory to SD Card.....	36
CUSTOMIZING THE CAMERA SETTINGS.....	37
Setup Menu and Features.....	39
Setting the Auto Off Time	39
Setting the Language	40
Setting the Date and Time.....	40
Setting the LCD Brightness.....	40
Formatting memory card	41
Turning Beep On or Off.....	42
Setting Quick View Interval	42
Setting AF Assist Light.....	43
RESTORE THE CAMERA TO FACTORY DEFAULT SETTINGS.....	44
SOFTWARE INSTALLATION GUIDE.....	45
Computer System Requirements	45
Installation Requirements	45
Using the Installer Splash Screen	46
Flow Diagram for Software Installation	47
Identifying your Operating System	48
Installing the Driver and DirectX 9 - Windows 98/98SE.....	49
Installing DirectX 9 - Windows 2000	51
Installing ArcSoft PhotoImpression - all Windows users.....	52
Installing Adobe Acrobat Reader 5 - all Windows users (optional).....	54
CONNECTING THE CAMERA TO THE COMPUTER	56
Downloading Pictures and Video Clips onto your Computer	56
Using ArcSoft PhotoImpression.....	57
Unplugging your Camera from the Computer	58
TV MODE	59
Connecting the camera to the television	59
Using the TV as a Live Viewfinder	59
Reviewing pictures and video clips on your TV	59
ERROR MESSAGES	60
TROUBLESHOOTING	61
GETTING HELP	65
CAMERA SPECIFICATIONS.....	66
SAFETY TIPS AND MAINTENANCE.....	69
REGULATORY INFORMATION.....	72

GETTING STARTED

ATTACHING THE WRIST STRAP

Please attach the wrist strap to prevent dropping the camera.

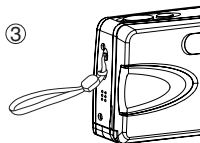
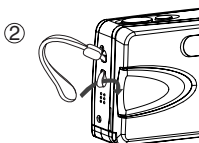
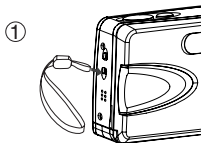

LOADING THE BATTERIES

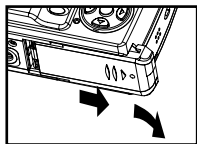

fig.1.1

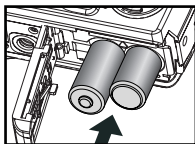

fig.1.2

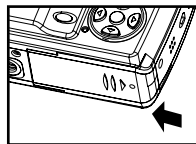





fig.1.3

The camera can use 2x AA alkaline, lithium or rechargeable batteries to operate. Rechargeable Batteries (NiMH) are highly recommended.

1. Slide the Battery/Memory Card door in the direction of the arrow, and lift it open. (fig.1.1)
2. Insert the batteries according to the polarity indication engraved on the battery contact. (fig.1.2)
3. Shut the Battery/Memory Card door by sliding it in the opposite direction of the arrow, and close it securely. (fig.1.3)

TURNING THE CAMERA ON AND OFF

The Power button is located on the top of the camera.

1. Press and hold the Power button () for more than 1 second to turn the camera on.
 - The Concord logo will show on the LCD for about 2 seconds.
 - If the camera is in Camera Mode () or Video Clip Mode (), the lens cover will open, and the lens will extend out automatically to the wide-angle position. Do not block the lens from extending out.
 - The LCD will turn on automatically and display live viewfinder.
2. To turn the camera off, press the Power () button.

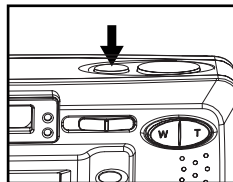

Note: To extend battery life,

- The LCD will be off after 1 minute of inactivity. After the LCD is automatically turned off, the Flash Ready LED blinks. Press any button to reactivate the LCD.
- The camera will automatically power off after 2 minutes of inactivity. Press and hold the Power () button for more than 1 second to turn the camera back on.

REMOVING THE PROTECTIVE PLASTIC FILM

To prevent the LCD from damaging during transportation, the LCD is covered with a clear plastic film. To get a clearer view of the subject while taking pictures, please remove the protective film.

SETTING THE LANGUAGE, DATE AND TIME

When the camera is powered on for the first time, the Language, Date and Time menus will appear.

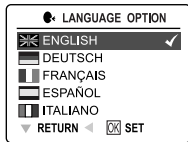

fig. 1.1

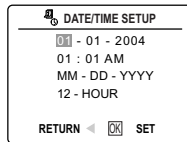

fig. 1.2

1. Press ▲ or ▼ to highlight the language you would like to use. (fig. 1.1)
2. Press the **OK** button to select. The next screen shows date/time setup page. (fig. 1.2)
3. Press ► to highlight the Date field, the Time field, the Date Format field or the Time Format field. The selected segment will blink.
4. Press ▲ or ▼ to change the number in the blinking position, and press ► to go to other fields.
5. Press the **OK** button to exit date/time setting. The next screen displays live viewfinder.

Note:

1. Each language will set the default setting for date format and TV option. To change the TV setting, please refer to page 59.

Language(s)	Date Format Setting	TV Option
English / Español / 日本語	MM/DD/YYYY	NTSC
Francis / Deutsch /Italiano/ Nederlands/Português	DD/MM/YYYY	PAL
中文	YYYY/MM/DD	PAL

2. If the battery is removed or dead for about 4 minutes, the date/time will return to its default setting. When you power on the camera again, the Date/Time setup screen will show on the LCD. You can either reset date/time by following steps 3-5 above or skip the date/time setting first by pressing the **OK** button and then set the date/time when you like by referring to p.40.

CHECKING THE BATTERY LEVEL

The battery level indicator represents the level of power of the batteries. The meaning of each icon is as follows:

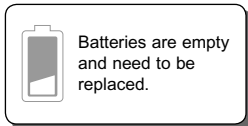
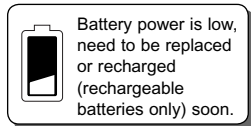
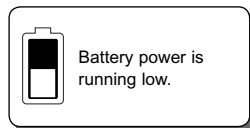
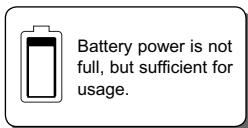
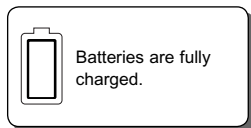

Note:

- The camera's battery level indicator may not accurately reflect the state of rechargeable batteries even when the rechargeable batteries have been fully recharged due to the inherent problem with rechargeable batteries. For better performance, please use Ni-MH rechargeable batteries.
- Remove the batteries from the camera if they will not be used for an extended period of time to prevent corrosion or battery leaks.

TURNING THE LCD/ICONS ON AND OFF

The camera has a 1.5" LCD which can frame subjects for image and video clip capture, review stored images, video clips and display the current camera settings.

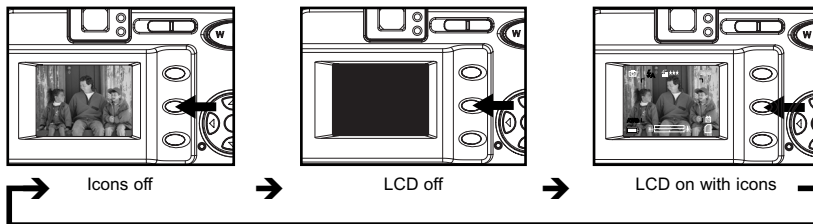

Use the () button to toggle the LCD mode. The LCD mode changes each time the button is pressed.

Note:

- To save battery power, you may turn off the LCD display.
- The LCD will also automatically power off after one minute of inactivity. The flash LED blinks when the LCD is auto-powered off. Press any button to turn the LCD back on.
- In () Review Mode, only the LCD icons can be turned on or off.

INTERNAL MEMORY/INSERTING THE MEMORY CARD

Internal Memory

The camera is equipped with 16MB of internal memory, which can be used right away.

Status	Memory in Use
Memory card is not inserted.	Internal Memory
Memory card is inserted.	Memory Card

NOTE! The files stored in the internal memory will remain in the internal memory until the Transferring Files feature is selected. Please refer to the Transferring Files section on page 36.

Inserting the Memory Card

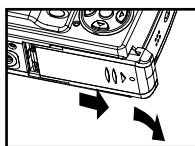

fig.1.1

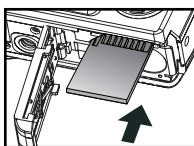

fig.1.2

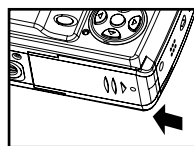

fig.1.3

In addition to having a 16MB internal memory, the camera can use Secure Digital (SD) memory cards to store images and video clips.

1. Slide the Battery/Memory Card door in the direction of arrow (fig. 1.1), and lift it open.
2. Insert the memory card in the direction as shown in fig.1.2, and push it firmly into the SD card slot as far as it will go. A click sound can be heard when the SD card is fully engaged.
3. Close the Battery/Memory Card door. (fig. 1.3) Make sure it is closed securely.

Removing the Memory Card

1. Press the memory card with finger-tip, the card will eject up.
2. Pull the card out.

Note:

- The camera can support SD cards up to 512 MB.
- When the SD card is inserted, power on the camera, the camera will first check if the SD card is valid. If yes, it will set the SD card as storage; otherwise it will request for formatting. Format the SD card (refer to p.41) if you want to use the SD card as storage, or else the memory locked icon will be shown on the LCD and Shutter button will be disabled.
- If the SD card is locked, when the camera is powered on, no image can be taken by pressing the Shutter button. In this case, please power off the camera first, then take out the SD card and unlock the SD card, and then reload the SD card.

SETTING THE CAMERA'S OPERATIONAL MODE

The camera has 3 operational modes: Camera Mode, Review Mode and Video Clip Mode.

To change the camera operational mode, slide the mode switch horizontally to the corresponding position.

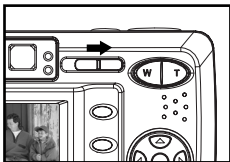

Camera Mode

Use the camera mode to take pictures or to customize your camera settings for picture taking.

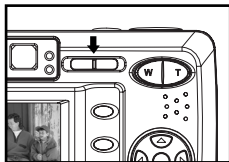

Review Mode

Use the review mode to browse through images and video clips, to delete images and video clips, to play a slide show, or to transfer the images/video clips from the internal memory to the SD card.

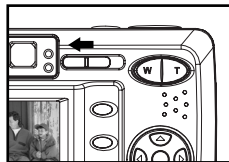

Video Clip Mode

Use video clip mode to capture video clips with sound or to customize your camera settings for video clip recording.

TAKING PICTURES

TAKING PICTURES WITH THE VIEWFINDER



fig.1.1

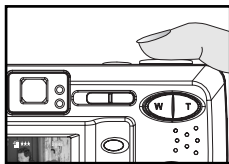

fig.1.2

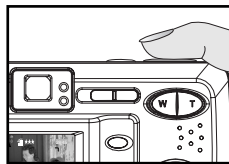

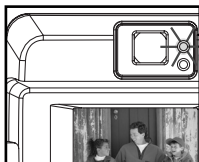

fig.1.3

1. Turn the camera on.
2. Set the camera to () Camera mode.
The LCD can be switched off to save battery power by pressing the () button.
3. Frame the subject in the viewfinder. (fig.1.1)
4. Press the **shutter** button half-way to activate the auto-focus until the green AF LED stops blinking. (fig.1.2)
 - The camera will automatically determine the best focus, and a rapid click sound can be heard.**Note:** For more information on Focus Lock, please go to page 11. To change AF mode, please refer to p. 24.
5. Press the **shutter** button fully to capture the image. (fig.1.3)
 - The camera will make a click sound.
 - The camera will beep when the image is captured.
 - When the image has been captured, the Flash Ready LED next to the viewfinder will blink to indicate that the image is being stored.

About Flash Ready LED



Steady

The camera is capturing a video clip.

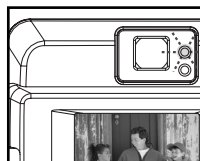

Blinking

The flash is recharging, or LCD is auto powered off.

Note: Do not power the camera off or change camera mode while the camera is capturing or storing a picture or video clip. Otherwise, the picture or video clip may be corrupted.

TAKING PICTURES WITH THE LCD



fig. 1.1

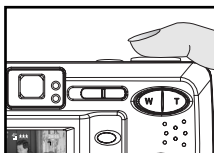

fig. 1.2

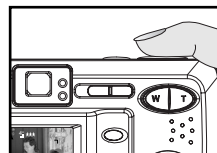



fig. 1.3

1. Set the camera to () camera mode.
2. Frame the subject in the LCD. (fig.1.1)
3. Press the **shutter** button half-way to activate the auto-focus lock until the green AF LED stops blinking and the AF frame turns green. (fig.1.2)
 - The camera will automatically determine the best focus, and a rapid click sound can be heard.

Note: For more information on Focus Lock, please go to p. 11. To change AF mode, please refer to p. 24.
4. Press the **shutter** button fully to capture the image. (fig.1.3)
 - The camera will make a click sound.
 - The camera will beep when the image is captured.
 - When the image has been captured, the Flash Ready LED next to the viewfinder will blink to indicate that the image is being stored.
 - A preview of the image will be displayed on the LCD for a second. To change the preview interval, please refer to p.42.
 - The picture counter number displayed in the LCD will be updated.
5. If you are not satisfied with the image, you may simply press () button to delete the image before it is saved. For details, please refer to p.30.

USING AUTO-FOCUS LOCK

This feature can be used to freeze the focus when the subject is not located in the center of the picture.

About Auto-Focus LED

When the **shutter** button is pressed half-way, the auto-focus feature will be activated and the Auto Focus (green) LED will display the status of the auto focus lock.

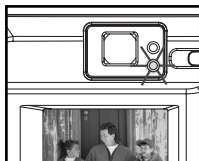

Steady
The subject is in focus.

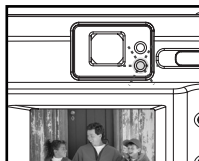

Blinking
The camera is setting the focus.

About Auto-Focus Frame



Auto-Focus Frame

AF Frame Color	Description
White	No focus.
Green	The subject(s) is in focus.

Using the focus lock:



fig. 1.1

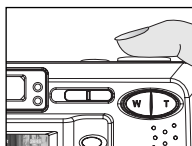

fig. 1.2



fig. 1.3

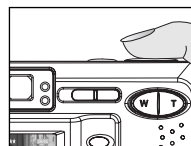

fig. 1.4

1. Position the subject in the frame center. (fig.1.1)
2. Press the **shutter** button halfway down until the AF frame turns green and the green AF LED stops blinking. (fig.1.2)
3. Recompose your picture. (fig.1.3)
Keep the shutter pressed half-way while recomposing the picture.
4. Press the **shutter** button fully to capture the picture. (fig.1.4)

Note: The AF LED will continue blinking in the following conditions:

1. There are several subjects at different distances within the focus lock area. Recompose the picture by moving the camera slightly.
2. There is no color contrast. Recompose the picture with a subject that contains more color.
3. There is insufficient lighting. Increase the lighting in the surrounding area.
4. Please refer to P.24 to change AF assist light setting.

SETTING THE FLASH



fig. 1.1

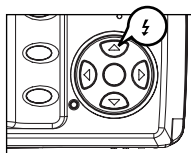

fig. 1.2



fig. 1.3

How to set the flash:

Press **▲** / **⚡** repeatedly until the desired indicator appears on the LCD.

Flash Mode	Description
⚡A Auto Flash (Default)	The camera judges if a flash is required. If the environment is too dark, the flash will fire.
⚡A 👁 Auto + Red-Eye	Use this mode to significantly reduce the occurrence of "red-eye" in flash photography. The camera will automatically detect when the flash is needed and the flash will fire after a short delay.
⚡ Flash ON	Flash will fire in any lighting condition. The "red-eye" reduction function is included also.
🚫 Flash off	The flash will not fire in this mode. Please use this mode if you want to capture the mood of the ambient lighting or to use the available light in places where flash photography is prohibited, such as museums. <ul style="list-style-type: none"> To prevent blurry pictures in low light situations, hold the camera steady when pressing the Shutter button or mount the camera on a tripod.

Note:

- The flash needs to recharge after it is fired. If the **Shutter** button is pressed while the flash is charging, the Flash Ready LED will blink. Please wait a few moments and press the **Shutter** button again to take a picture.
- Some of the Scene Selection Modes will deactivate the flash setting. Please refer to p.20 for more information.

USING THE OPTICAL ZOOM

The camera provides up to 3x optical zoom to take pictures.

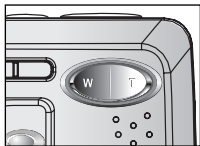

fig. 1.1



fig. 1.2



fig. 1.3

1. Press **T** (Tele) to zoom in your subject.

The optical zoom status is shown on the LCD by the zoom bar in white color ().

2. Press **W** (Wide) to zoom out.

USING THE DIGITAL ZOOM

The camera also provides 6x Digital Zoom (six times). Combined with the 3x optical zoom, it can give up to 18x magnification to your pictures.



fig. 1.1



fig. 1.2

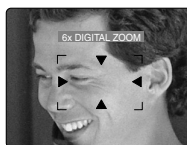





fig. 1.3

How to use digital zoom:

1. Turn the LCD on.
2. Press **T** until the white optical zoom bar reached the mid-marker ().
3. Continue to press **T** to activate the digital zoom. The zoom bar will turn blue () first. When digital zoom reaches 6x, the zoom bar will change to red () and the focus mark will change as show in fig. 1.3. The captured area is within the red arrows.
 - There will be a short delay before the digital zoom is activated.
4. Press **W** to zoom out.

Activating/Deactivating Digital Zoom

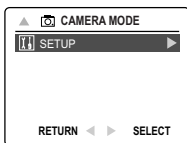

fig. 1.1

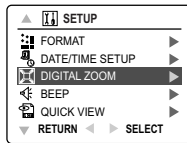

fig. 1.2

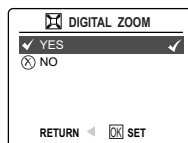

fig. 1.3

1. In Camera Mode, press **MENU** to display the Main Menu.
2. Press **▼** until **SETUP** is highlighted, then press **▶** to enter its submenu.
3. Press **▼** until **Digital Zoom** is highlighted, then press **▶** to enter its submenu.
4. Press **▲** or **▼** to highlight Yes or No.
 - The default setting is Yes.
5. Press **OK** to select.

Important:

1. Hold your camera steady while using Digital Zoom to prevent blurriness in the photograph due to camera movement. It is recommended to either place your camera on a steady surface or use a tripod.
2. For best results, stand at least 2 ft (0.6m) away from the subject in normal mode.
3. The image quality may degrade slightly with Digital Zoom.
4. Digital Zoom can only be monitored with the LCD and not through the optical viewfinder.

TAKING PICTURES IN MACRO MODE (CLOSE-UP SHOOTING)

This mode enables the camera to capture pictures in close distances.

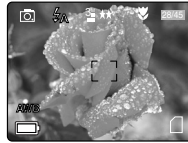
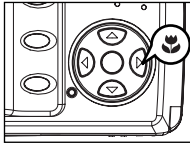



1. Press the **▶** button. The Macro icon () will be displayed on the LCD.
2. Frame the subject in the LCD.
 - The best shooting range is from 10 cm to 60 cm. (4 in. – 23.6 in.)
3. Press the **shutter** button half-way to activate the focus until the green AF LED stops blinking and the AF frame turns green.
4. Press the **shutter** button fully to take the picture.

Note:

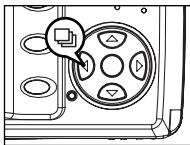
1. When Macro mode is selected, the camera will turn the LCD on if it is turned off automatically.
2. Zoom buttons will not work in Macro mode.

TAKING CONTINUOUS PICTURES

1. Press the **◀** button. The Continuous Shot icon () will be displayed on the LCD.
2. Frame the subject in the LCD screen and press the **shutter** button half-way to activate the focus until the green AF LED stops blinking and the AF frame turns green.
3. Press the **shutter** button fully to capture the pictures.
 - The camera will automatically capture 7 continuous images at approximately 3 images per second in 1600 x 1200 resolution.
4. If you do not want to take continuous pictures anymore, press the **◀** button once until the Continuous Shot icon () disappears from the LCD.

Note:

- In continuous shooting mode the flash is disabled as the recharging time will slow it down.
- The camera will only capture pictures in 1600 x 1200 resolution in continuous shooting mode.
- The LCD will be blank when the images are taken in the Continuous Shooting Mode.

TAKING PICTURES WITH SELF-TIMER

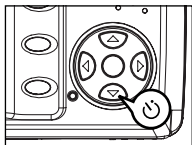

1. In () Camera Mode, press ▼ button, the self-timer icon () appears on the LCD.
2. Place the camera on a flat surface or tripod.
3. Use the LCD to compose the picture, and then press the **Shutter** button to activate the Self-Timer.
The Self-timer LED will blink slowly for 7 seconds, faster for the remaining 3 seconds and then the image will be captured.

Note:

- The Self-Timer is automatically deactivated once the image is taken.
- To deactivate the Self-Timer before taking a picture, press ▼ button until the self-timer icon () disappears.

Photography Hints -

Since the Self-Timer LED indicator on the front of the camera flashes, you have time to join in the photograph and know when the camera is done taking a picture when the Self-Timer LED light stops blinking.

USING THE MAIN MENU IN CAMERA MODE

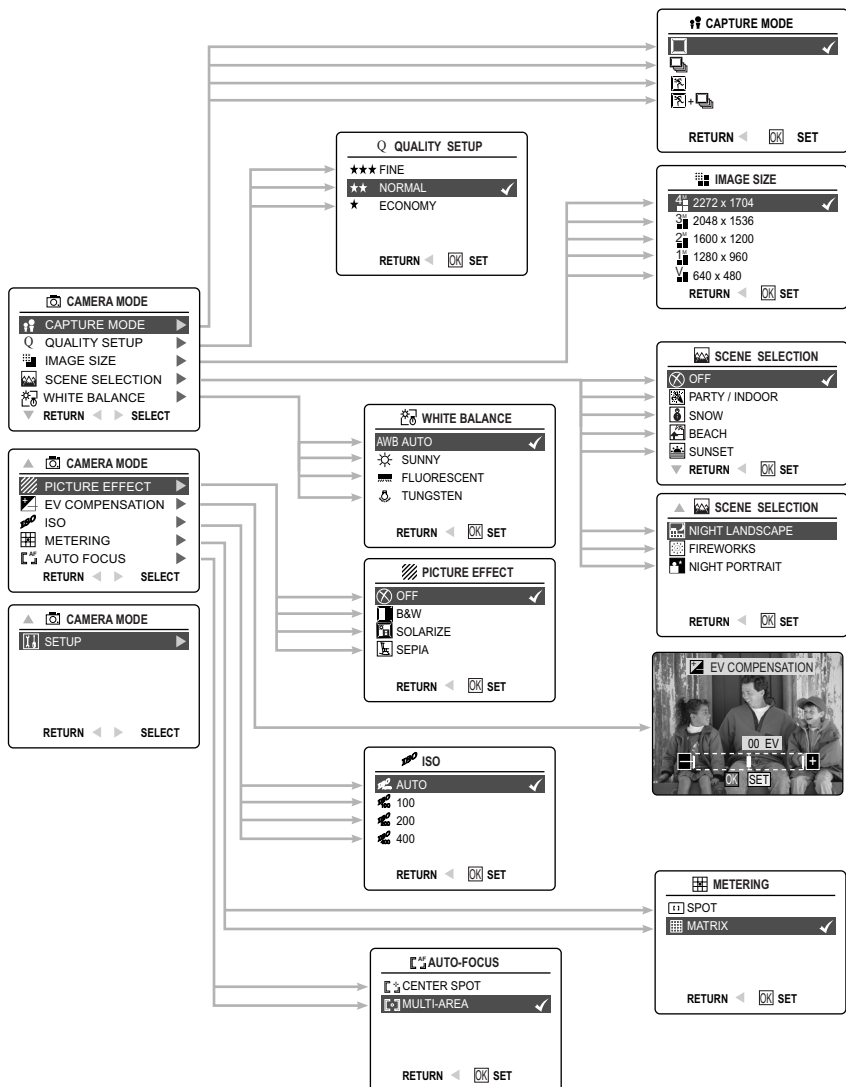





USING THE MAIN MENU IN CAMERA MODE

Follow the steps below to set the advanced shooting options in the camera through the Main Menu.

1. Turn the camera on.
2. Set the mode switch to () Camera mode.
3. Press the **MENU** button to display the main menu.
4. Press **▲** or **▼** until the desired option is highlighted.
5. Press **▶** to enter the submenu.
6. Press **▲** or **▼** in the submenu to toggle between the options.
7. Press the **OK** button to make a selection.
 - All selections will be marked by a red check mark.
8. To return to the previous menu, press **◀**.
9. To exit the menu at any time, press the **MENU** button.

SETTING CAPTURE MODE

The capture mode menu has 4 features to choose from for taking pictures.

Capture Mode Option	Description
() Single	The camera will take 1 picture at a time.
() Continuous Shooting	The camera will take 7 pictures (at 1600 x 1200 resolution) in a row when the shutter button is fully pressed. The flash is disabled in this mode.
() Sport	The camera will take 1 picture at a time in Sport mode.
( + ) Continuous Shooting with Sport	The camera will take 7 pictures in a row in Sport mode



Note: Flash will be deactivated in continuous shot.

TAKING PICTURES IN SPORT MODE

This mode is used to shoot sports and other high-speed activities. The camera will automatically choose a higher shutter speed and wider aperture to capture fast-moving action without blur.

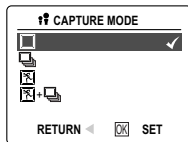
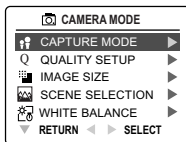
Setting Sport Mode:



1. In the main menu, press **▶** to enter the capture mode submenu.
2. Press **▲** or **▼** to highlight Sport () or Sport + Continuous shot ( + ).
3. Press **OK** to enter the mode.

Taking a picture in Sport Mode:

1. Frame the subject in the LCD.
2. Press the **shutter** button half-way to activate the focus until the green AF LED stops blinking and the AF frame turns green.
3. Press the **shutter** button fully to take the picture.

Note: Hold your camera steady to prevent blurriness. It is recommended to either place your camera on a steady surface or use a tripod.

SETTING IMAGE QUALITY

The Image Quality setting determines the amount of compression used to reduce the size of the stored image file in order to economize space in the memory.

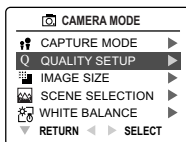

Quality	JPEG Compression Ratio	Description
Fine	4.5:1	Fine image quality can be used for making prints.
Normal (Default)	11:1	Normal image quality can be used for general purpose pictures.
Economy	17:1	Economy image quality can be used for pictures that will be sent via e-mail.

How to change the quality:

1. When (Q) Quality is highlighted, press ► to enter the (Q) Quality Setup submenu.
2. Press ▲ or ▼ until the desired setting is highlighted.
3. Press the **OK** button to select the Quality mode.
4. Press the **MENU** button to return to picture taking mode.

SETTING IMAGE RESOLUTION

Image Resolution determines the size of a captured image. Higher resolution images contain more details and have larger file sizes.

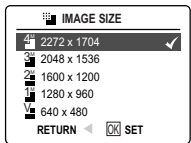
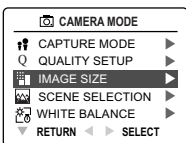

Images Stored on 16MB memory (approx.):

Resolution \ Quality	4MP (2272 x 1704)	3MP (2048 x 1536)	2MP (1600 x 1200)	1.3MP (1280 x 960)	VGA (640 x 480)
Fine	14	16	23	33	94
Normal	32	37	52	77	200
Economy	46	53	81	110	248

Images Stored on 32MB memory (approx.):

Resolution Quality	4MP (2272 x 1704)	3MP (2048 x 1536)	2MP (1600 x 1200)	1.3MP (1280 x 960)	VGA (640 x 480)
Fine	27	31	45	63	188
Normal	64	74	105	144	378
Economy	93	102	145	202	478

Images Stored on 64MB memory (approx.):

Resolution Quality	4MP (2272 x 1704)	3MP (2048 x 1536)	2MP (1600 x 1200)	1.3MP (1280 x 960)	VGA (640 x 480)
Fine	54	62	93	130	372
Normal	129	147	217	288	774
Economy	186	204	290	404	956

Images Stored on 128MB memory (approx.):

Resolution Quality	4MP (2272 x 1704)	3MP (2048 x 1536)	2MP (1600 x 1200)	1.3MP (1280 x 960)	VGA (640 x 480)
Fine	111	127	181	257	776
Normal	254	300	434	603	1565
Economy	372	378	605	893	1980

How to change the resolution:





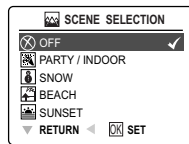
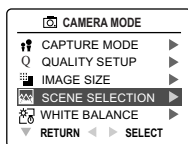

1. When Resolution is highlighted in the Main Menu, press ► to enter the () Resolution submenu.
2. Press ▲ or ▼ until the desired setting is highlighted.
3. Press the OK button to select the mode
4. Press the MENU button to return to picture taking mode.

Note: The default image resolution is 4MP.

SELECTING SCENE MODES

The preset scene modes are helpful to quickly optimize the various settings to get the best capture of specific scenes.



Preset Scene	Description
Off (default)	No Scene Selection.
 Party/Indoor	Use this mode to capture the details of candlelit scenes or other indoor background light conditions.
 Snow	Use this mode to capture the details in snow scene, since the snow reflects more of the light and would make the images look darker if the camera is set at Off mode.
 Beach	Use this mode to capture the details in shining water scene.
 Sunset	This mode captures the deep hues and color variations in sunsets and sunrises.
 Night Landscape	A slow shutter speed is used to capture the lights in night scenes. Photography Tip: With the slow shutter speed there is a possibility of getting blurry images due to camera movement. To reduce blurring, you may do the following: 1. Set your camera to Night Landscape mode. 2. Place your camera on a tripod or sturdy surface area. 3. Set the camera to Self-Timer mode. 4. Press the shutter button.
 Fireworks	Use this mode to capture the burst of light from fireworks with a slower shutter speed.
 Night Portrait	Use this mode to capture a subject illuminated with the lights in a night scene with a slow shutter speed. <ul style="list-style-type: none"> • Due to the slow shutter speed, place the camera on a tripod for better picture quality.

How to set the scene selection:

1. When Scenes Select is highlighted, press **▶** to enter its submenu.
2. In the Scene menu, press **▲** or **▼** to choose between the options.
3. Press the **OK** button to select the Scene mode.
4. Press the **MENU** button to return to picture taking mode.

Note: Any change of the flash setting will cancel the scene selected in Scene Selection.

SETTING WHITE BALANCE

By default the camera uses Auto White Balance to best reproduce colors under different lighting conditions. For mixed lighting conditions you can use the Auto White Balance.

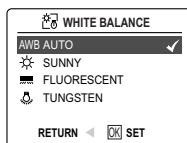
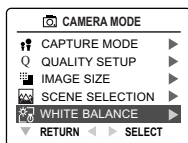

White Balance Mode	Description
Auto	The camera will automatically choose the white balance setting. Use this setting in variable light conditions.
Sunny	Use outdoors with sufficient sunlight.
Fluorescent	Use indoors with fluorescent or ambient light conditions.
Tungsten	Use indoors with tungsten light conditions.

How to change the White Balance:

1. When White Balance is highlighted, press **▶** to enter its submenu.
2. Press **▲** or **▼** until the desired setting is highlighted.
3. Press the **OK** button to select the White Balance mode.
4. Press the **MENU** button to return to picture taking mode.

SELECTING THE PICTURE EFFECT

You can shoot with different picture effects.

Picture Effect	Description
OFF (Default)	Taking pictures without effect.
B&W	Taking pictures in black and white.
SOLARIZE	Taking pictures with clear light intensity like illustrations.
SEPIA	Taking pictures in sepia tones like old pictures.

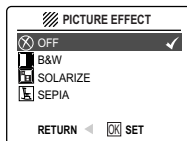
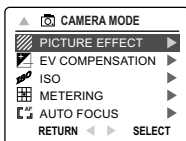

How to set photo effect:

1. When Picture Effect is highlighted, press **▶** to enter its submenu.
2. Press **▲** or **▼** until the desired setting is highlighted.
3. Press the **OK** button to select the picture effect.
4. Press the **MENU** button to return to picture taking mode.

SETTING EXPOSURE COMPENSATION

The camera uses Auto Exposure to give you well exposed pictures under most conditions. If the main subject turned out too light or too dark, you can use the Exposure Compensation feature to improve the result.

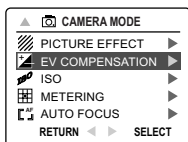





Exposure Compensation Mode	Description
+	Increasing the Exposure in pictures that are too dark, will make the picture lighter.
-	Decreasing the Exposure in pictures that are too light, will make the picture darker.

How to use Exposure Compensation:

1. Press ▲ or ▼ in the Main Menu until () Exposure Compensation is highlighted.
2. Press ► display the Exposure Compensation bar on the LCD.
3. Press ◀ or ▶ to change the Exposure Compensation between – 2.0 to +2.0.
4. Press the **OK** button to select the desired value.
 - The camera will return to picture taking mode automatically after selecting.

SETTING THE ISO SENSITIVITY

Raise the ISO speed when you wish to reduce camera shake or to turn the flash off when shooting in a dark area.

ISO Setting	Description
 Auto (default)	Equivalent to setting of 100 under normal conditions. When lighting is poor, camera raises sensitivity automatically to compensate.
 100	100 is best when you want to shoot clear, sharp images in daylight.
 200	200 is ideal when shooting in cloudy situations.
 400	400 is best when shooting in dark lit surrounding, for example, when shooting at night.

Note: Higher ISO speeds increase image noise. To take clean images, use as low an ISO speed as possible.

How to change ISO setting:

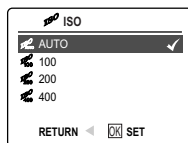
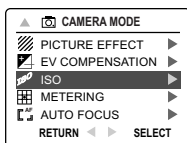

1. When () ISO is highlighted, press **▶** to enter its submenu.
2. Press **▲** or **▼** until the desired setting is highlighted.
3. Press the **OK** button to select the ISO setting.
4. Press the **MENU** button to return to picture taking mode.

SETTING LIGHT METERING MODE

You can choose which part of the image to use to measure the brightness and determine the exposure.

Metering Mode	Description
Spot	Meters the light in the center area of the image. Use this mode when the subject is backlit or surrounded by strong light.
Matrix(default)	Metering the light in different zones. Use this mode when the lighting condition is complex. The camera can adjust the settings to correct exposure for the main subject by metering the position of the subject, the brightness, the direct light, and the backlighting etc.

How to change Light Metering mode:

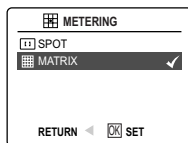
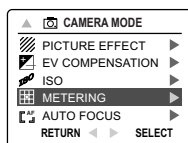

1. When () Metering is highlighted, press **▶** to enter its submenu.
2. Press **▲** or **▼** until the desired setting is highlighted.
3. Press the **OK** button to select the metering mode.
4. Press the **MENU** button to return to picture taking mode.

SETTING AUTO FOCUS (AF) MODE

The camera provides two AF modes to perform the Auto Focus function.

AF Mode	Description
Center Spot	In this mode, the camera uses the center zone of the subject to perform auto focusing. Use this mode when the subject is backlit or surrounded by strong light.
Multi-Area (default)	In this mode, the camera automatically determines which zone (center, upper-left, upper-right, lower-left, lower-right) to use to perform the auto focusing. Use this mode when the lighting condition is complex.

How to set AF mode:

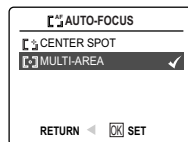
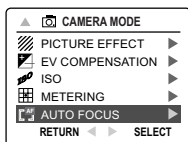

1. When AF mode is highlighted, press **▶** to enter its submenu.
2. Press **▲** or **▼** until the desired setting is highlighted.
3. Press the **OK** button to select the metering mode.
4. Press the **MENU** button to return to picture taking mode.

TAKING VIDEO CLIPS

The camera can capture video clips with sound.

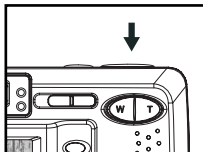
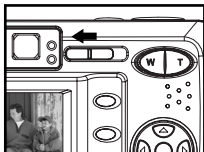

To record a video clip:

- Slide the Mode Switch to () Video Clip Mode.
 - The time limit is showing on the upper right corner of the screen.
- Position the subject in the LCD.
- Press the **shutter** button half-way to activate the focus until the green AF LED stops blinking and the AF frame turns green.
- Press the **shutter** button fully to capture a continuous video clip. The time recorded will be shown on the LCD. The camera can take video until the memory is full.

To stop recording:

- Press the **Shutter** button again to stop recording.
- OR
- The camera will continue recording until the memory limit has been reached.



Video Clip Information



Resolution: QVGA (320x240) or
 QQVGA (160x120) (Best for e-mail)
 Frame rate: 30fps
 File Format: AVI (Motion Picture)

Note:

- Do not open the battery door or turn the camera off while recording. Otherwise the video clip may not be stored.
- Higher capacity memory cards can take longer video clips.
- The Flash, Macro, and Continuous Shooting are deactivated in video clip mode.

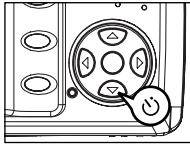
TAKING VIDEO CLIP WITH SELF-TIMER



1. In the () Video Clip Mode, press **▼** button, and the self-timer icon () will appear on the LCD.
2. Place the camera on a flat surface or tripod.
3. Use the LCD to compose the picture, and then press the **Shutter** button to activate the Self-Timer. The Self-timer LED will blink slowly for 7 seconds, faster for the remaining 3 seconds and then starts recording the video clip.
4. Press **Shutter** button again to stop recording. Otherwise the camera will continue until the memory limit is reached.

USING THE MAIN MENU IN VIDEO CLIP MODE

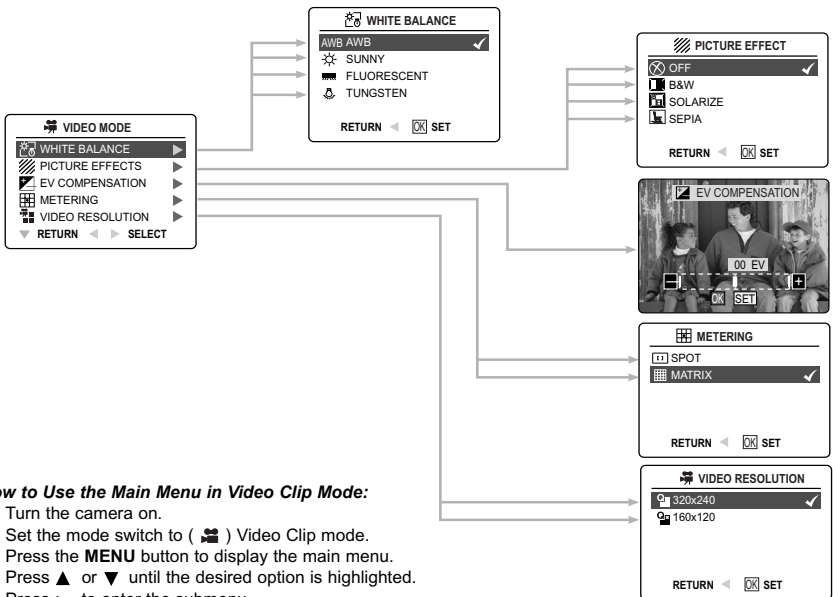
**How to Use the Main Menu in Video Clip Mode:**

1. Turn the camera on.
2. Set the mode switch to () Video Clip mode.
3. Press the **MENU** button to display the main menu.
4. Press **▲** or **▼** until the desired option is highlighted.
5. Press **▶** to enter the submenu.
6. Press **▲** or **▼** in the submenu to toggle between the options.
7. Press the **OK** button to make a selection.
 - All selections will be marked by a red check mark.
8. To return to the previous menu, press **◀**.
9. To exit the menu at any time, press the **MENU** button.

Note:

- Please go to P.21 to get to know the differences between the various White Balance settings.
- Please refer to P.21 to see the different picture effects.
- Please go to P.22 for information about Exposure Compensation.
- Please refer to P.24 for the metering difference.

SETTING VIDEO CLIP RESOLUTION

Note: 160x120 resolution is ideal for email.

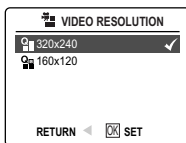
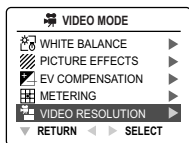
How to change the video resolution:

1. When Video Resolution is highlighted in the Main Menu, press ► to enter the () Resolution submenu.
2. Press ▲ or ▼ until the desired setting is highlighted.
3. Press the **OK** button to select the mode
4. Press the **MENU** button to return to video clip mode.

REVIEWING YOUR FILES



REVIEWING THE PICTURES/VIDEO CLIPS

In () review mode, you can review your stored pictures and video clips through the LCD.

Note: When a memory card is inserted in the camera, only the pictures stored in the memory card will be displayed in the review mode. To view the pictures in the internal memory, please transfer files from internal memory to the SD card (p.36). Or, turn the camera off, remove the memory card, and then turn the camera back on.

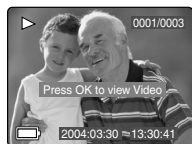
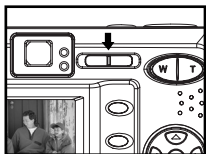
How to review pictures/video clips:



1. Slide the Mode Switch towards (). The lens will retract after 30 seconds in review mode.
2. Press  or  to scroll through each file.
 - The file type and frame counter will be displayed on the LCD.

File Indication	File Type
JPEG	Still Picture
AVI	Video Clip

0001/0003

Number of total pictures /video clips

Number of current picture/video clip

3. When a video clip icon (**AVI**) is displayed on the LCD, press the **OK** button to play the video clip. To stop playing the video clip, press the **Shutter** button again.

Note: You may press the **OK** button to pause and resume playing the video clip.

ENLARGING THE PICTURES

In () Review Mode, you can enlarge your pictures to take a closer look at the subject on the LCD. This feature is for viewing purposes only and it will not enhance the stored picture.

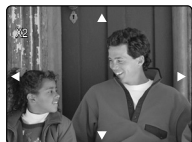

2x Enlargement



4x Enlargement



6x Enlargement

Resolution	Maximum Enlargement
2272 x 1704	6X
2048 x 1536	4x
1600 x 1200	4x
1280 x 960	4x
640 x 480	2x

How to enlarge:

1. In () Review Mode, press ◀ or ▶ to scroll through the stored pictures and video clips.
2. While viewing a stored still picture, press the T button to get different magnifications.
3. Press ▲, ▼, ◀ or ▶ to navigate in the picture. When the picture can pan no farther in one direction, the directional arrow will disappear.
4. Press W button to zoom out.

Note: Video Clips cannot be magnified.

REVIEWING YOUR FILES IN THUMBNAIL

The thumbnail view can be accessed in () Review mode by pressing either Menu or Wide button.



fig. 1.1

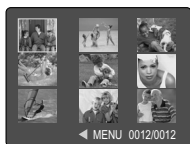















fig. 1.2

Using the Quick Access Button:

1. In the () Review Mode, press W button, nine thumbnail images or video clips will appear on the LCD display in a few seconds. The last displayed picture will come first and bordered in red. (fig. 1.2)
2. Press , ,  or  to look through all the pictures and video clips. The selected picture or video clip will have a red border. And the type of the video clip files and its sequence number will also be shown on the bottom of the LCD.
3. Press the **OK** button to view the picture or video clip in full screen.

Using the review menu:

1. In () Review Mode, press **MENU** to enter review menu.
2. Press  or  to highlight Thumbnail.
3. Press  button to have nine thumbnail images or video clips appear at once on the LCD display.
4. Press , ,  or  to look through all the pictures and video clips.
5. Press the **OK** button to view the picture or video clip in full screen. Or press the **MENU** button to return to the previous screen.

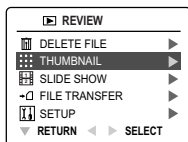



USING THE DELETE BUTTON TO DELETE YOUR FILES

You can delete your files in Quick View, Thumbnail or in Review mode by using the Delete button.

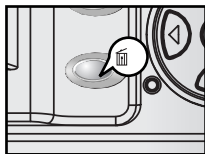

Note: Once a file is deleted, it cannot be recovered.



Deleting in Quick View Mode (Camera Mode)





1. In the () Camera mode, after a picture is taken, the LCD will show the picture for a second. If you are not satisfied with the picture, press the  button, the screen will read "Are you sure?"

Note: To change the quick view time, please go to p.42.





2. Press  or  to highlight No or Yes.
3. Press the **OK** button to select.
 - If Yes is selected, the picture will be deleted.
 - If No is selected, the picture will be saved.

Deleting in Review Mode



Delete One

1. In () Review mode, press  button once, the screen will read "Are you sure?"
2. Press  or  to highlight No or Yes.
3. Press the **OK** button to select.
 - If No is selected, no change will be made, and the camera will return to the review mode.
 - If Yes is selected, the file will be deleted.

Delete All

1. In () Review mode, press  button twice, the screen will read "Delete All, Are you sure?"
2. Press  or  to highlight No or Yes.
3. Press the **OK** button to select.
 - If No is selected, no change will be made, and the camera will return to the review mode.
 - If Yes is selected, all the files will be deleted.

Deleting in Thumbnail Review Mode

1. When thumbnail view is displayed (refer to P.30), select the image you want to delete, press  button, the LCD shows the image in full screen and asks "Are You Sure?"
2. Press  or  to highlight No or Yes.
3. Press the **OK** button to select.
 - If No is selected, no change will be made, and the LCD will return to the thumbnail view mode.
 - If Yes is selected, the selected file will be deleted.

USING THE REVIEW MENU

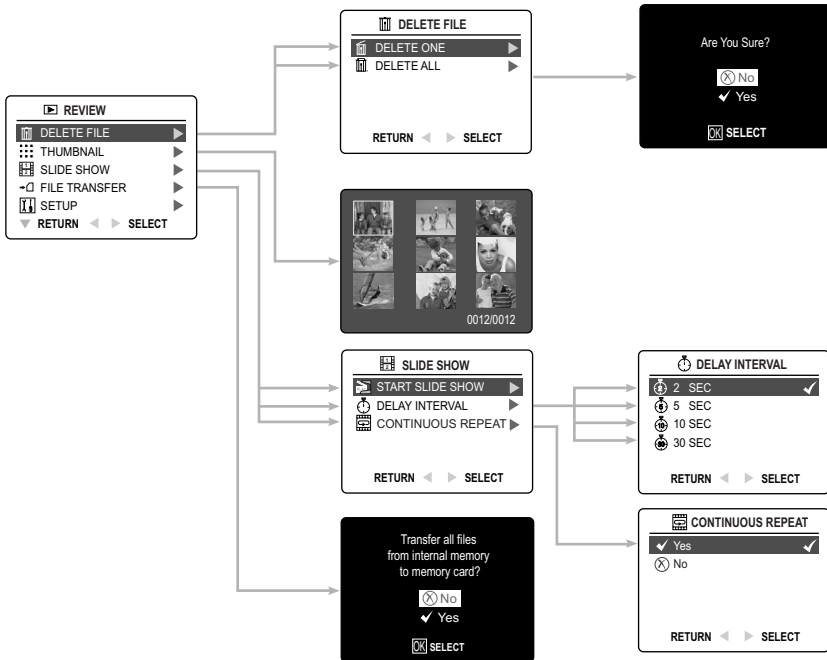
**How to use the Menu in Review mode:**

1. Turn the camera on.
2. Set the Mode Switch to () Review mode.
3. Press the **MENU** button to display the main menu.
4. Press **▲** or **▼** until the desired option is highlighted.
5. Press **▶** to enter its submenu.
6. Press **▲** or **▼** in the submenu to toggle between the options.
7. Press the **OK** button to make a selection.
 - All selections will be marked by a red check mark.
8. To exit the menu, press **◀**.
9. To exit the menu at any time, press the **MENU** button.

DELETING YOUR FILES

Note: Once the files are deleted, they cannot be recovered.

Deleting One File by Using the Review Menu

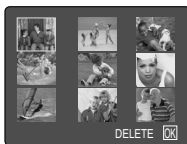
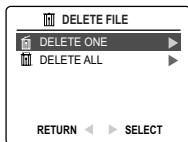

1. In () Review mode, press the **MENU** button to enter review menu.
2. Press **▲** or **▼** to highlight Delete File.
3. Press **▶** to enter its submenu.
4. Press **▲** or **▼** to highlight Delete One, then press **▶** . The LCD will show the images/video clips in thumbnail.
5. Press **▲** , **▼** , **◀** , **▶** to highlight the file you want to delete.
6. Press **OK** button. The next screen will read "Are You Sure?"
7. Press **▲** or **▼** to highlight No or Yes.
8. Press the **OK** button to select.
 - If No is selected, no change will be made, and the camera will return to the thumbnail view mode.
 - If Yes is selected, the selected file will be deleted, and the LCD return to the thumbnail view mode.

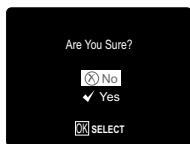
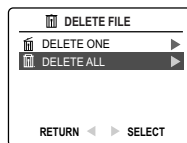

Deleting All Files

1. In () Review Mode, press **MENU** to enter review menu.
2. Press **▲** or **▼** to highlight Delete File.
3. Press **▶** to enter its submenu.
4. Press **▲** or **▼** to highlight Delete All.
5. Press **▶** . The next screen will read "Are You Sure?"
6. Press **▲** or **▼** to highlight No or Yes.
7. Press the **OK** button to select.
 - If No is selected, no change will be made, and the LCD will return to the previous screen.
 - If Yes is selected, all file will be deleted. The LCD will show "No Files!"

RUNNING A SLIDE SHOW

Use the slide show feature to automatically display your pictures and videos on the camera LCD screen at a selectable interval rate. You can also run a slide show on any video device that is equipped with a video input, such as a television or digital projector.

The slide show feature is available when you have at least one picture stored.

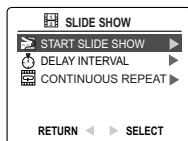
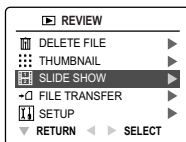

How to run a slide show:

1. In () Review Mode, press **MENU** to enter review menu.
2. Press **▲** or **▼** to highlight Slide Show.
3. Press **▶** to enter its submenu.
4. Press **▶** when Start Slide Show is highlighted to begin the Slide Show.
 - Pictures: Each picture will be shown for 2 seconds. To change the display interval, please refer to the instructions below.
 - Video clips: The full video clip will be displayed.
5. Press **▲** or **▼** once to speed up or slow down the rate of slide show.
6. Press **◀** or **▶** to force to the previous or next image.
7. Press **OK** to pause or resume slide show.
8. To quit the Slide Show, press the Menu button.

Note: When an SD memory card is inserted into the camera, only the pictures stored in the memory card will be displayed. To view the pictures in the internal memory, please transfer the files onto the SD card (p.36) or remove the SD card.

How to set the slide show interval:

The default slide show interval is 2 seconds. You can change the time following the steps below:

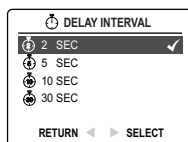
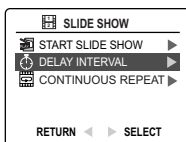
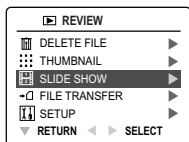

1. In () Review Mode, press **MENU** to enter review menu.
2. Press **▲** or **▼** to highlight Slide Show.
3. Press **▶** to enter its submenu.
4. Press **▲** or **▼** to highlight Delay Interval.
5. Press **▶** to enter the submenu.
6. Press **▲** or **▼** to select how long each picture is displayed on the LCD: 2, 5, 10 or 30 seconds.
7. Press **OK** to select.
8. Press **◀** to return to the previous menu. Or press **MENU** to exit.

How to set repeatedly slide show

By default, the slide show will stop automatically when the last frame is played. However, you can set the camera to play the slide show repeatedly by following steps below:

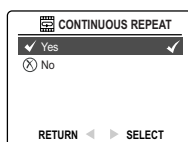
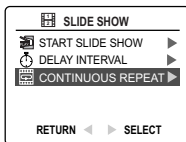
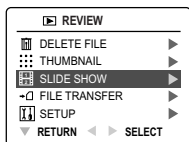

1. In () Review Mode, press **MENU** to enter review menu.
2. Press **▲** or **▼** to highlight Slide Show.
3. Press **▶** to enter its submenu.
4. Press **▲** or **▼** to highlight CONTINUOUS REPEAT.
5. Press **▶** to enter the submenu.
6. Press **▲** or **▼** to select Yes or No.
 - If Yes is selected, the camera will play the slide show repeatedly after you started playing a slide show.
7. Press **OK** to select.
8. Press **◀** to return to the previous menu. Or press **MENU** to exit.

TRANSFERRING FILES FROM INTERNAL MEMORY TO SD CARD

The camera allows you to transfer photos and video clips that are stored in the camera's internal memory to an SD memory card.

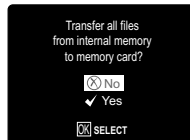
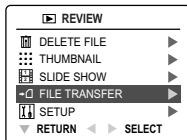

1. In () Review Mode, press Menu to enter review menu.
2. Press or to highlight File Transfer.
3. Press . The next screen will read "Transfer all files from internal memory to memory card"?
4. Press or to highlight No or Yes.
5. Press **OK** to select.
 - If No is selected, no change will be made, and the LCD will return to the previous screen.
 - If Yes is selected, the screen reads "Transferring ..." and all files will be transferred to the SD card.

TRANSFERRING FILES ...

Note:

1. Please insert a memory card with 16MB or more of available memory. If the SD card memory isn't enough for the storage of all the files in the internal memory, the camera will leave the remaining images/video clips in the internal memory and displays "Memory Full" message and the Memory card locked icon ().
2. If the SD card is locked, the camera will show memory card locked icon for about 2 seconds and then back to the main menu.

CUSTOMIZING THE CAMERA SETTINGS

EN

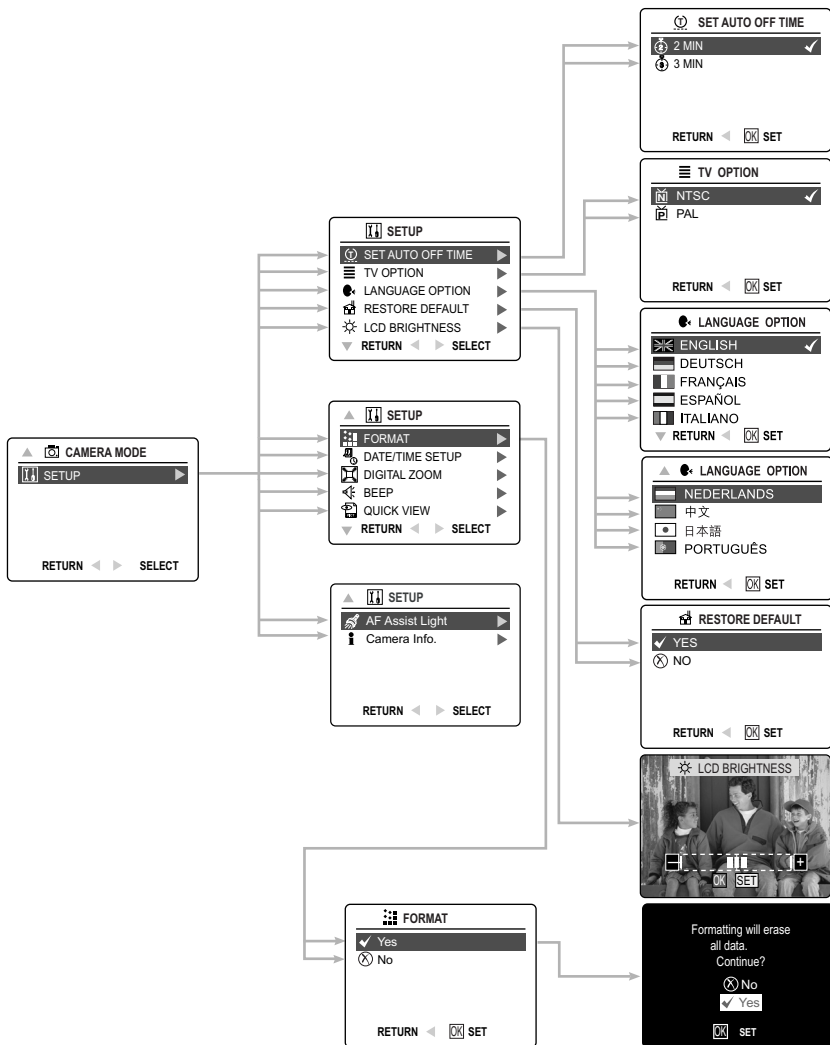

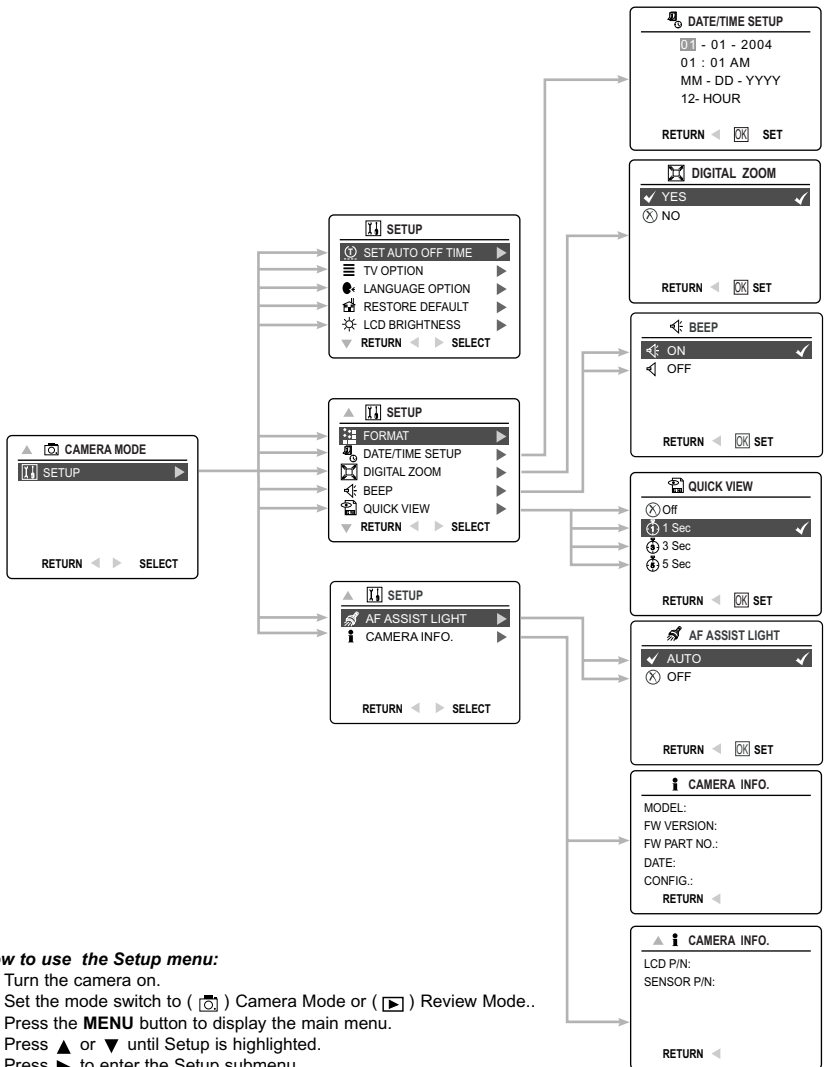

How to use the Setup menu:

1. Turn the camera on.
2. Set the mode switch to () Camera Mode or () Review Mode..
3. Press the **MENU** button to display the main menu.
4. Press **▲** or **▼** until Setup is highlighted.
5. Press **▶** to enter the Setup submenu.
6. In the Setup menu, press **▲** or **▼** to highlight the option you wish to customize.
7. Press **▶** to enter the submenu of the highlighted option.
8. Use the arrow buttons to adjust the setting and press the **OK** button to select.
9. Press **◀** to return to the previous menu OR press the **MENU** button to exit.

SETUP MENU AND FEATURES

Setup Setting	Options	Description
Set Auto Off Time	2 min, 3 min	This feature enables the camera to automatically turn off when it is idle.
TV Option	NTSC, PAL	Sets the mode the camera needs to adapt to your TV. (Page 59)
Language Option	English Deutsch Français Español Italiano Nederlands 中文 日本語 Português	Sets the language in your camera. (Page 40)
Restore Default	Yes/No	Sets all camera settings to the factory default. (Page 44)
LCD Brightness		Sets the LCD brightness level. (Page 40)
Format	Yes/No	Formats the memory card by deleting all files. (Page 41)
Date/Time Setup	Date/time, Date/time format	Changes the date/time in your camera and their display format.
Digital Zoom	Yes No	Activates/deactivates the digital zoom.
Beep	On, Off	Activates or deactivates the beep sound.
Quick View	Off, 1 sec., 3 sec., 5 sec.	Sets quick view interval.
AF Assist Light	Auto, Off	
Camera Info	Model FW Version FW Part No. Date Config. LCD P/N Sensor P/N	Displays the camera version information. This is for information purposes only.

SETTING THE AUTO OFF TIME

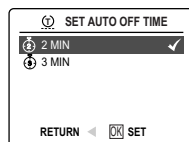
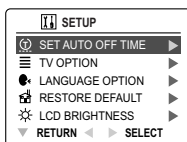
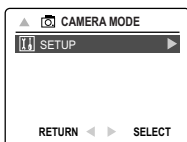

1. In the Setup menu, press ▲ or ▼ until SET AUTO OFF TIME is highlighted.
2. Press ► to enter the submenu.
3. Press ▲ or ▼ to highlight the preferred choice.
4. Press the **OK** button to set.

Notes: The default setting is 2 minutes. Press the Power button for more than 1 second to reactivate the camera after it goes off.

SETTING THE LANGUAGE

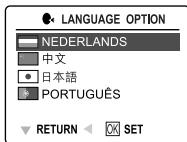
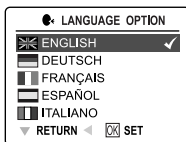
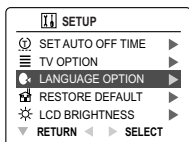

To set the Language:

1. In the Setup menu, press ▲ or ▼ until Language is highlighted.
2. Press ► to enter the Language submenu.
3. Press ▲ or ▼ to highlight the desired language.
4. Press the OK button to set.

SETTING THE DATE AND TIME

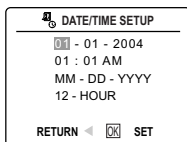
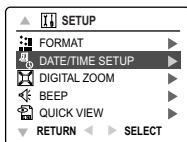

1. In the Setup menu, press ▲ or ▼ until DATE/TIME SETUP is highlighted.
2. Press ► to enter the submenu.
3. Press ► to highlight the date/time fields and date/time format. The selected segment will blink.
4. Press ▲ or ▼ to change the number in the blinking position, and press ► to go to other fields.
5. After the date/time is set, press the OK button to quit date/time setting. The next screen displays live viewfinder.

SETTING THE LCD BRIGHTNESS

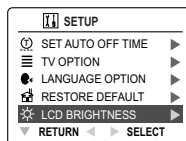
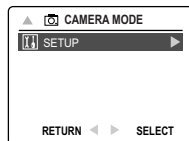

How to set the LCD Brightness:

1. In the Setup menu, press ▲ or ▼ until LCD Brightness is highlighted.
2. Press ► to display the LCD Brightness bar on the LCD.
3. Press ◀ or ▶ to adjust the brightness.
4. Press the OK button to select.

FORMATTING THE INTERNAL MEMORY OR MEMORY CARD

CAUTION: !



1. Formatting deletes all pictures and video clips from the memory.
2. Removing the card during formatting may damage the card.
3. Selecting the formatting feature while there is no memory card in the camera, will cause the internal memory to format. All pictures and video clips on the internal memory will be lost.

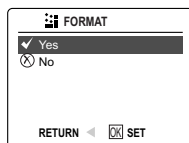
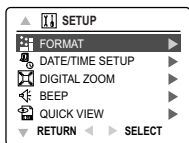

1. In the Setup menu, press ▲ or ▼ until Format is highlighted.
2. Press ► to enter the Format submenu.
3. Press ▲ or ▼ to highlight No or Yes.
4. Press the **OK** button to select.
 - If No is selected, no change will be made, and the LCD will return to the previous screen.
 - If Yes is selected, the LCD shows "Formatting will erase all data. Continue?"



5. Press ▲ or ▼ to highlight No or Yes.
6. Press the **OK** button to select.
 - If No is selected, no change will be made, and the LCD will return to the Setup Menu.
 - If Yes is selected, the LCD shows "Formatting ..." ALL FILES will be deleted.

Note: If "CARD ERROR!" is displayed on the LCD screen, it indicates that the memory card is corrupted. Please format the memory.

TURNING THE BEEP SOUND ON OR OFF

The camera provides an option to enable or disable the beep sound. The beep sound is ON by default. While the beep sound is on, the camera will beep in any of the following situations:

- When the camera is powered on.
- After an image is captured. (Note: The beep after image capture cannot be disabled.)
- When any button, except for the Power button, the zoom buttons and the camera mode slide switch button, is pressed.

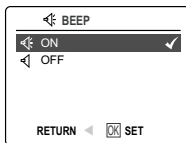
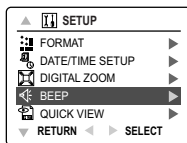

How to activate/deactivate the beep sound:

1. In the Setup menu, press ▲ or ▼ until Beep is highlighted.
2. Press ► to enter its submenu.
3. Press ▲ or ▼ to highlight the desired selection.
4. Press the OK button to set.

SETTING QUICK VIEW INTERVAL

The camera provides programmable Quick View duration, which is the time that the image is shown to the user immediately after a picture is taken.

Quick View	Description
Off	No quick view, remain in live viewfinder.
1 sec (Default)	Display image for 1 seconds then return to live viewfinder.
3 sec	Display image for 3 seconds then return to live viewfinder.
5 sec	Display image for 5 seconds then return to live viewfinder.

How to select Quick View time phrase:

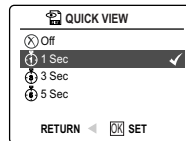
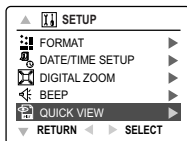

1. In the Setup menu, press ▲ or ▼ until Quick View is highlighted.
2. Press ► to enter its submenu.
3. Press ▲ or ▼ to highlight the desired selection.
4. Press the OK button to set.

SETTING AF ASSIST LIGHT

The camera can turn the built-in AF (Auto Focus) assist light on to illuminate the focus subject in low-light situation.

AF Assist Light	Description
Auto (Default)	The camera will turn on AF assist light if it is needed.
Off	The camera will not turn on the AF assist light even if the subject is in a low-light condition.

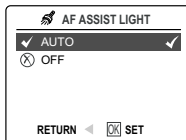
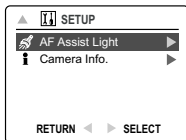
How to change AF assist light setting:

1. In the Setup menu, press ▲ or ▼ until AF Assist Light is highlighted.
2. Press ► to enter its submenu.
3. Press ▲ or ▼ to highlight the desired selection.
4. Press the **OK** button to set.

RESTORE THE CAMERA TO FACTORY DEFAULT SETTINGS

To restore the default settings in your camera:

1. Press **▶** when Restore Default is highlighted in the camera.
2. Press **▲** or **▼** to highlight **No** or **Yes**, and then press **OK**.
 - When No is selected, no change is made. The LCD returns to the previous screen.
 - When Yes is selected, the LCD shows "Are you sure?"
3. Press **▲** or **▼** to highlight **Yes** or **No**, and then press **OK**.
 - If **No** is selected, no change will be made. The LCD returns Setup page.
 - If **Yes** is selected, the camera will be reset to the factory default setting. The LCD will show "Restoring..." for a few seconds and then return to setup page. The Default settings will be restored.

Note: Please refer to the table below for the default settings.

OPTION	DEFAULT STATUS
Camera Mode	Single Shot
Image Size	2272 x 1704
Quality	Normal
Flash	Auto Flash
White Balance	Auto
LCD Brightness	Center (0)
Scene Selection	OFF
Digital Zoom	Yes
Exposure Compensation	0
ISO	Auto
Metering	Matrix
Photo Effect	None
Time Out	2 min
Slide show interval	2 Seconds
Beep	ON
Quick View	1 Sec
AF Mode	Multi-Area
Continuous Repeat	No
AF Assist Light	Auto
TV Mode	NTSC for USA/Japan, PAL for Europe/Asia
Date/Time Format	USA/Japan: MM/DD/YYYY, 12-hour Europe/Asia: DD/MM/YYYY, 24-hour

SOFTWARE INSTALLATION GUIDE

The software that comes with the Concord Eye-Q 4363z includes driver, reader, and photo editing programs. These programs transfer the pictures or video clips from your camera to your computer, and enable you to view them on your computer screen. The following are the computer system requirements for these programs to be installed.

Computer System Requirements

Windows

- 300MHz Pentium II processor or equivalent.
- Microsoft Windows 98/98SE, Windows Me, Windows 2000 Professional, Windows XP Home / Professional / Media Center
- 360MB free hard disk space .
- 128MB of RAM
- Minimum 800 x 600 display with 16-bit color (1024 x 768 with 24-bit color or better recommended)
- USB Port
- 4x CD-ROM Drive

Macintosh

- Mac OS 9.0, 9.1, 9.2 and X 10.1 or later
- Power PC-based
- 32MB of RAM
- 640 x 480 display with Thousands of colors (Millions of colors recommended)
- Built-In USB Port

Installation Requirements

The installer will automatically detect which software applications need to be installed or if they are not necessary. Please read the installation requirements before proceeding with the installation process.

System	Windows 98/98SE	Windows Me	Windows 2000	Windows XP	Macintosh
Install Camera Driver	X				
Install DirectX 9	X		X		
Install ArcSoft PhotoImpression	X	X	X	X	
Install Adobe Acrobat Reader 5					
Camera automatically detected by the computer (no driver installation required)		X	X	X	X

USING THE INSTALLER SPLASH SCREEN

The installer will automatically detect which software applications need to be installed or if they are not necessary. This will be indicated by the buttons on the splash screen that appears when the CD-ROM is inserted into the computer:



Color	Description
Yellow (●)	Required or highly recommended to install.
Gray (●)	Already installed or not necessary

Option	Description
Camera Drivers	The USB Mass Storage camera drivers enable the camera to become an external drive on your computer.
Microsoft DirectX 9	DirectX 9 enables the movie playback applications on your computer to playback video clips that are captured with the camera.
ArcSoft PhotoImpression 2000	This photo software enables you to edit and enhance pictures.
Adobe Acrobat Reader 5	Adobe Acrobat Reader enables you to view the electronic version of the User's Guide.
User's Guide	Direct link to the electronic version of the User's Guide in different languages. (All User's Guides are saved in PDF format.)

FLOW DIAGRAM FOR SOFTWARE INSTALLATION

To transfer the pictures and video clips from the memory card, the camera must be connected to a computer with the provided Mini-USB cable. Additional setup may be required by some operating systems before connecting the camera to the computer for the first time.

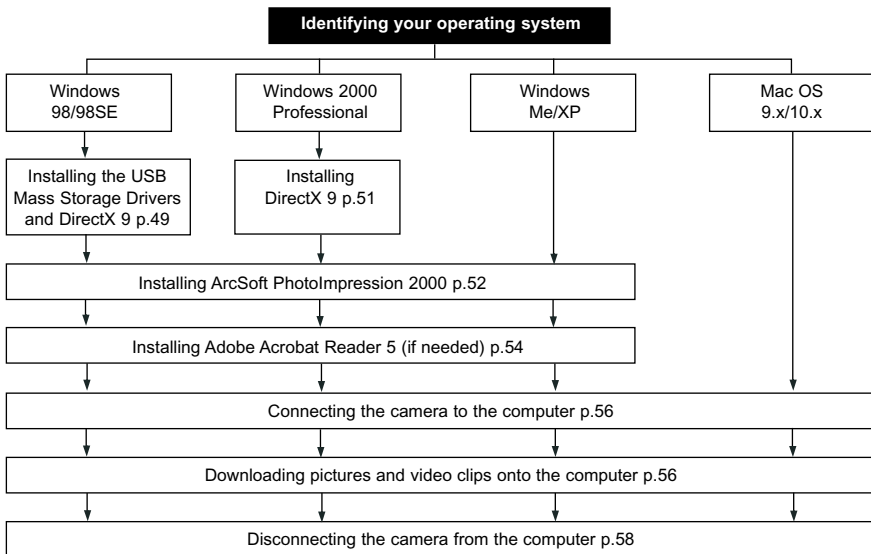

Data transfer may not function correctly if you have one of the operating systems listed below or you are using an add-on USB adapter or USB hub.

- Windows 95
- Windows NT 3.51/4.0
- Mac OS 8.6 or lower.
- Home built computer systems or computer systems without a factory installed operating system.
- Home installed operating system or upgrade to the operating system.

IDENTIFYING YOUR OPERATING SYSTEM

Windows

1. Right click the **My Computer** icon on your desktop, and go to Properties.
2. The System Properties Box will appear.
The information about your computer is listed under the system area.
3. Confirm that your computer is running one of the following operating systems and proceed to the page in the chart for installation instructions:



System	Proceed to page
Windows 98, Windows 98 Second Edition	Page 49
Windows 2000	Page 51
Windows Millennium Edition, Windows XP Home Edition, Windows XP Professional Edition, Windows XP Media Center Edition	Page 52

4. Press **OK** to close the window

For Windows 98/98SE/Me/2000, if the **My Computer** icon is not on your desktop, click **Control Panel** icon from the Start Menu and double click on the **System** icon to open the System Property Box.

For Windows XP, if the My Computer icon is not on your desktop, click Control Panel icon from the Start Menu and click on the Performance and Maintenance icon, then click on the System icon to open the System Property Box.



Macintosh



1. In the Apple Menu on the Menu bar, select **About this Computer**.
2. A window will appear with the computers operating system version. Confirm that your computer is version 9 or higher.

No installation of software is necessary for Macintosh users, please go to Page 56 to connecting your camera to the computer.



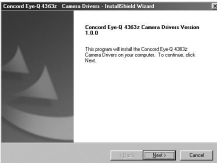
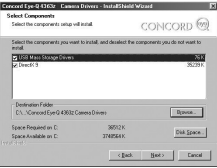

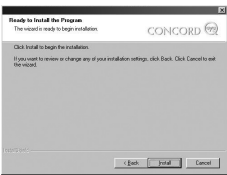
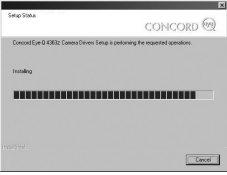
INSTALLING THE DRIVER AND DIRECTX 9 – WINDOWS 98/98SE

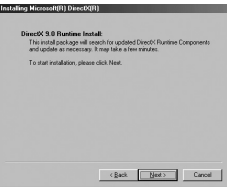
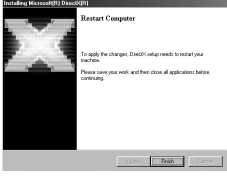
NOTE: Do not connect the camera to your computer before the camera drivers and Microsoft DirectX 9 installation is completed.

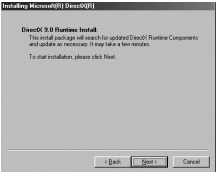

Step 1	Make sure your camera is powered off and not connected to the computer.
Step 2	Make sure the computer is powered on and Windows 98 or 98SE is running.
Step 3	Close any other applications or software you may be running.
Step 4	<p>Insert the supplied CD-ROM into your computer's CD-ROM Drive.</p> <p>NOTE: If the installer does not start automatically within 30 seconds after the CD-ROM has been inserted, click on "My Computer" either on the Desktop or in the Start Menu and locate the CD-ROM Drive. Double click on the CD-ROM Drive icon for installation and proceed to Step 5.</p>
Step 5	<p>Select the language. Click [OK].</p> 
Step 6	<p>The installation screen will appear. Click on Install Camera Drivers.</p> 
Step 7	<p>Click [Next >].</p> 
Step 8	<p>The next dialog will prompt you to select the components that will be installed. USB Mass Storage Driver and DirectX 9 will be preselected.</p> <p>The files will be saved in the Concord Eye-Q 4363z directory automatically.</p> <p>OR</p> <p>You may change the default folder by clicking [Browse...] and selecting a different folder in your computer.</p> <p>Click [Next >].</p> 

<p>Step 9</p>	<p>Click [Install].</p>	
<p>Step 10</p>	<p>Install progress bar</p>	
<p>Step 11</p>	<p>The next screen will begin the DirectX setup. Select " I accept the agreement " then click [Next >].</p>	
<p>Step 12</p>	<p>Click [Next >].</p>	
<p>Step 13</p>	<p>Click [Finish]. Your computer will automatically restart.</p>	

INSTALLING DIRECTX 9 – WINDOWS 2000



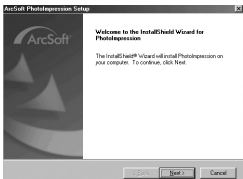
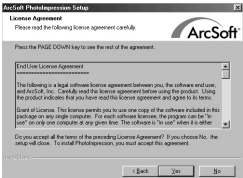

Step 1	Make sure your camera is powered off and not connected to the computer.
Step 2	Make sure the computer is powered on and Windows 2000 is running.
Step 3	Close any other applications or software you may be running.
Step 4	Insert the supplied CD-ROM into your computer's CD-ROM Drive. NOTE: If the installer does not start automatically within 30 seconds after the CD-ROM has been inserted, click on "My Computer" either on the Desktop or in the Start Menu and locate the CD-ROM Drive. Double click on the CD-ROM Drive icon for installation and proceed to Step 5.
Step 5	Select the language. Click [OK] . 
Step 6	The installation screen will appear, click on Install Microsoft DirectX 9.0 . 
Step 7	The next screen will begin the DirectX setup. Select " I accept the agreement " then click [Next >] . 
Step 8	Click [Next >] . 
Step 9	Click [Finish] . Your computer will automatically restart. 

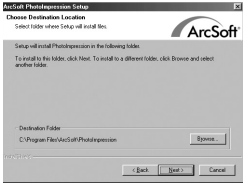
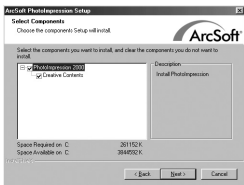
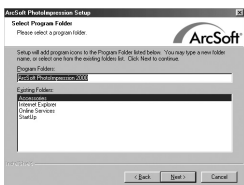
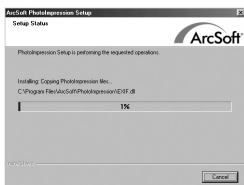
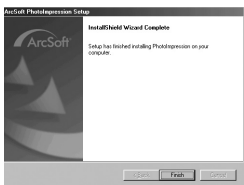

INSTALLING ARCISOFT PHOTOIMPRESSION – ALL WINDOWS USERS

Step 1	Make sure your camera is powered off and not connected to the computer.
Step 2	Make sure the computer is powered on and Windows is running.
Step 3	Close any other applications or software you may be running.
Step 4	Insert the supplied CD-ROM into your computer's CD-ROM Drive. NOTE: If the installer does not start automatically within 30 seconds after the CD-ROM has been inserted, click on "My Computer" either on the Desktop or in the Start Menu and locate the CD-ROM Drive. Double click on the CD-ROM Drive icon for installation and proceed to Step 5.
Step 5	Select the language. Click [OK] . 
Step 6	The installation screen will appear. Click on Install ArcSoft PhotoImpression 2000 . 
Step 7	Click [Next >] . 
Step 8	Click [Yes] . 

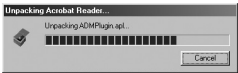
EN	<p>Step 9 Click [Next >].</p>	
<p>Step 10</p>	<p>Make sure all two applications are checked and then click [Next >].</p>	
<p>Step 11</p>	<p>Click [Next >].</p>	
<p>Step 12</p>	<p>The screen will show the status of the installation.</p>	
<p>Step 13</p>	<p>Click [Finish].</p>	

INSTALLING ADOBE ACROBAT READER 5- ALL WINDOWS USERS (OPTIONAL)

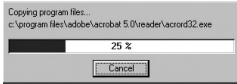
Step 1	Make sure your camera is powered off and not connected to the computer.
Step 2	Make sure the computer is powered on and Windows is running.
Step 3	Close any other applications or software you may be running.
Step 4	<p>Insert the supplied CD-ROM into your computer's CD-ROM Drive.</p> <p>NOTE: If the installer does not start automatically within 30 seconds after the CD-ROM has been inserted, click on "My Computer" either on the Desktop or in the Start Menu and locate the CD-ROM Drive. Double click on the CD-ROM Drive icon for installation and proceed to Step 5.</p>
Step 5	<p>Select the language. Click [OK].</p> 
Step 6	<p>The installation screen will appear, Click on Install Adobe Acrobat Reader 5.</p> 
Step 7	<p>Status bar</p> 
Step 8	<p>Click [Next >].</p> 

<p>EN</p> <p>Step 9</p>	<p>The files will be saved into C:\Program Files\Adobe\ Acrobat 5 automatically.</p> <p>OR</p> <p>You may change the default folder by clicking [Browse... and selecting a different folder in your computer.</p> <p>Click [Next >].</p>	
<p>Step 10</p>	<p>Installation progress</p>	
<p>Step 11</p>	<p>Select Yes, to restart the computer or No, to restart the computer later.</p> <p>Click [Finish >].</p>	

CONNECTING THE CAMERA TO THE COMPUTER

Note for Windows 98 and 98SE users: Do not connect the camera to your computer before the camera drivers and Microsoft DirectX 9 installation is completed.

1. Power the camera on.
2. Connect the camera to the computer with the Mini-USB cable provided.
 - Plug the larger end of the Mini-USB cable that is included with the camera into your PC's USB port. (Please refer to your computer's documentation for more information on the location of the USB port.)
 - Plug the small end of the Mini-USB cable into the USB port located in the Cable Connection panel on the side of the camera.
3. When the camera is connected to the computer for the first time, the camera USB Mass Storage driver installation will begin. Please follow the on-screen instructions to complete the installation.

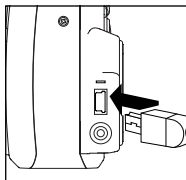

DOWNLOADING PICTURES AND VIDEO CLIPS ONTO YOUR COMPUTER

Note: Windows 98/98SE users must install the camera driver and DirectX 9 first. (Page 49)

Note: Windows 2000 users must install DirectX 9 to view video clips on the computer. (Page 51)

Downloading files from the camera:

- Internal memory: Do not insert the memory card.
- Memory Card: Insert the memory card.

Caution: Do not attempt to open the battery/memory door to insert or remove the memory card and/or batteries when the camera is connected to the computer.

FOR WINDOWS USERS

Downloading Pictures and Video Clips onto your computer:

1. Connect the camera to the computer.
2. Double-click on My Computer.
3. Double-click Removable Disk.
4. Double-click DCIM.
5. Double-click 100_4363.
 - The pictures (JPEG) and video clips (AVI) stored in the memory will be displayed.
6. Click and drag the files into a directory in your computer to save them.
 - To select all files, click Edit > Select all.

FOR MACINTOSH USERS

1. Connect the camera to the computer.
 - After a few moments, the external hard drive will appear on the desktop.
2. Double-click the "CONCORD" removable drive that is on your desktop.
3. Double-click DCIM.
4. Double-click 100_4363.
 - The stored pictures (JPEG) and video clips (AVI) stored in the memory will be displayed.
5. Drag and drop the image you want to save in the computer.
 - To select all files, click Edit > Select all.

Note: You may also transfer the stored pictures and video clips onto your computer by using a memory card reader (sold separately.)

USING ARCSOFT PHOTOIMPRESSION (WINDOWS ONLY)

1. Connect the camera to the computer.
2. Launch ArcSoft PhotoImpression software by clicking on Start-Programs-ArcSoft Camera Suite and choosing PhotoImpression from the application list on your screen. (fig. 1.1)



fig. 1.1



fig. 1.2

3. When the Application opens, click on the Camera/Scanner button.(fig. 1.2)
4. Click on the drop-down list under Select Source and choose Concord Camera.
5. Click on the Camera/ Scanner Icon ().
 - A second window will appear showing the contents (pictures) in the memory, and options on how to handle them. (fig. 1.3)

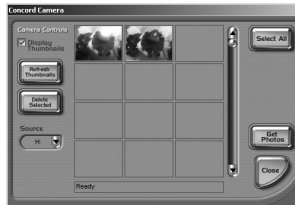

fig. 1.3

6. Select the picture you would like to view, edit or save by clicking on it. The selected image will be highlighted by a border. You may also click on Select All to choose all pictures.
7. Click on Get Photos.
The pictures will then be added to your album at the bottom of the application (fig. 1.4).



fig. 1.4

8. Click on Close to close the Camera Controls windows (as shown in fig. 1.3).
9. Double-click on the thumbnail or click on OK to open the photo.
10. Click on Edit to edit the photo. You may, for example,
 - Resize the photo by using the "Crop/Resize" tools.
 - Modify the photo by using the "Retouch" tools. For example, to remove red-eyes.
 - Add some text onto the photo by using the "Text" tools.
11. Click on Save to save the photo. Two options "Save" and "Save As" will be offered.
12. Click on Print to print the photo. You can choose one preferred way of printing: Standard Printing, Greeting Card/Multiple Printing or Thumbnail Printing.



UNPLUGGING YOUR CAMERA FROM THE COMPUTER

Windows 98/98SE:

1. Double-click on My Computer.
2. Right-click on Removable Disk to display the menu.
3. Click on Eject in the menu.
4. Unplug the Mini-USB from the camera.



fig.1.1

Windows ME/2000/XP:

1. Turn the camera off.
2. Click once on the "Unplug or Eject Hardware" icon on the right hand side of your task bar. (fig.1.1)
3. Select "Stop Concord Eye-Q 4363z USB Mass Storage Device"
4. Click [OK] in the "Safe to Remove Hardware" prompt.
5. Unplug the Mini-USB from the camera. (fig.1.2)

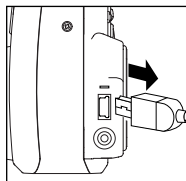

fig.1.2

Macintosh:



1. Drag the "CONCORD" removable drive icon on the desktop to the Trash.
2. Unplug the Mini-USB cable from the camera.

TV MODE

CHANGING THE TV MODE SETTING

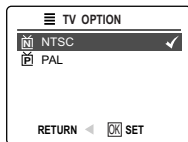
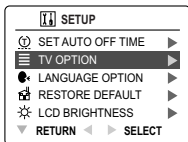
The camera allows you to view individual files and to take pictures and record clips on the television. To begin, check your television documentation to determine what video standard you should set your camera to either NTSC or PAL.



1. Slide the Mode switch to () Camera mode or () Review mode.
2. Press the **MENU** button.
3. Press **▲** or **▼** until Setup is highlighted.
4. Press **▶** to enter the Setup menu.
5. In the Setup menu press **▲** or **▼** until TV is highlighted
6. Press **▶** to enter the TV submenu.
7. Press **▲** or **▼** to change the setting to NTSC or PAL and press OK.
8. Press the **MENU** button to exit.

CONNECTING THE CAMERA TO THE TELEVISION

1. Connect the red sound terminal of the AV cable to the sound terminal marked AUDIO of your TV, and connect the yellow image terminal of the AV cable to the image input terminal jack marked VIDEO or VIDEO IN on your television.
2. Turn on your television.
3. Set the television to video mode according to the instructions in the owner's manual. (This is usually channel 3, 4 or AV).
4. Connect the other end of the cable into the VIDEO port located in the cable connection panel.

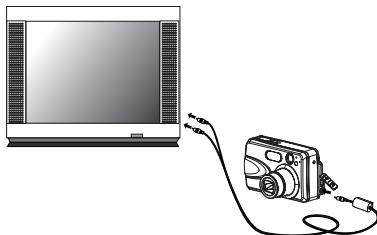

USING THE TV AS A LIVE VIEWFINDER

1. Connect the camera to the TV.
2. Turn the camera on.
3. Slide the Mode Switch to () Camera mode.
4. The TV will become a live viewfinder.



Note: You may record your TV Mode session by using your VCR. Please refer to your VCR documentation to learn more about recording.

REVIEWING PICTURES AND VIDEO CLIPS ON YOUR TV

1. Connect the camera to the TV.
2. Turn the camera on.
3. Slide the Mode Switch to () Review mode.
4. Press **▲** or **▼** to scroll through the saved pictures and video clips.
 - When an AVI file is displayed on the TV, press the **OK** button to view the video clip. The sound will be played via the TV set at the same time.
5. To view more options, press the **MENU** button to display the menu on the TV screen. Please refer to page 32/37 for further information.

ERROR MESSAGES

Error Messages appears on the LCD when the memory is full or there is problem with the SD card.

Error Message	Cause	Solution
Memory Full	Memory (either internal memory or SD card) is full.	Follow one of the below methods: 1) Delete unwanted files. 2) Insert an SD card, or replace the SD card with a new one. 3) Transfer the photos/video clips onto your computer.
Memory Full 	The SD card memory isn't enough to hold the files saved in the internal memory. Only part of the files in the internal memory is transferred.	Follow one of the below methods: 1) Delete unwanted files. 2) Insert an SD card, or replace the SD card with a new one. 3) Transfer the photos/video clips onto your computer.
Memory Error	The camera's internal memory may be corrupted.	Format the memory (P. 41) first. If the problem remains after formatting, that means the internal memory is corrupted. You can either to use an SD card as storage or send the camera for repairing.
Card Error	The SD card may be corrupted.	Format the SD card first. If the problem still exists after formatting, you can only replace the SD card with a new one.
Incompatible Media Formatting will erase All data Continue?	The memory card is not recognizable (maybe it's new or used on other digital cameras).	Format the SD card.
	The memory card is locked.	Turn off the camera, take out the SD card and unlock the SD card.
No Card	No SD card is inserted while trying to transfer the files.	Insert an SD card with enough free memory.
Format Error	The internal memory or the SD card is corrupted.	Change to use SD card as storage or replace the SD card with a new one.

TR E U B L E S H O O T I N G

SYMPTOM	POSSIBLE CAUSE	POSSIBLE SOLUTION
CAMERA		
Cannot turn on the camera.	Batteries were not installed correctly.	Install batteries correctly by following the indication engraved on the edge of the battery compartment or that on the battery contact.
	Batteries are dead or weak.	Replace batteries.
	Battery door was not closed correctly.	Close the battery compartment properly.
The camera buttons do not work.	The camera needs to be reset.	Press the reset button on the back of the camera with a pointed object, such as a pen, then power the camera off then on.
The camera turns off during usage.	The batteries are drained of power.	Replace the batteries with new ones.
PICTURES/VIDEO CLIPS		
Picture/Video clip has poor image quality.	Poor Lighting.	Increase the lighting in the surrounding area when taking pictures and video clips.
	Lens is dirty.	Clean the lens with a soft cloth. See the Camera Maintenance section.
	Subject is too close.	Stand at least 2 ft. (0.6m) away from the subject in the normal mode. At Macro mode, stand 4" (10cm) away from the subject.
TAKING PICTURES		
Flash picture taken is too light.	Subject is too close.	Move the subject further away from the camera.
	The flash is not needed.	Change the camera setting to Auto Flash. See p.12.
	Lighting condition is too bright.	Decrease exposure compensation. See p.22.
Flash Picture taken is too dark.	The subject is too far away for the flash to be effective.	Move the subject closer to the camera, or move the camera closer to the subject.
	Flash is not on.	Turn the flash On.
	The subject is in front of a bright light.	Change the subject's position.
	Lighting condition is too dark.	Increase the exposure compensation. See p.22.

SYMPTOM	POSSIBLE CAUSE	POSSIBLE SOLUTION
Flash did not work.	There was sufficient flash for the picture and the flash did not fire. This happens when the camera is set to Auto Flash.	This is normal as your camera's electronic light sensor is programmed to only fire the flash when needed.
	Camera's flash has been turned off.	Turn the flash to Auto flash.
	Flash did not charge.	Verify that the Ready LED has stopped blinking before taking a picture.
Picture taken is blurry.	Subject or camera was moved as the picture was taken.	Hold the camera steady until the picture is taken.
	The focus was not locked before taking the picture.	Before taking a picture, press the shutter button half-way to lock the focus, and press the shutter button fully to capture the picture. (p.11)
There is something wrong with the color of the photographs.	White balance is not set properly.	Reset the white balance feature to Auto, or for the specific lighting in the surrounding area.
Cannot take a picture or a video clip.	Memory is full.	Delete unwanted pictures and continue shooting.
		Download the stored files to your PC and delete the files from the memory card.
		Insert a memory card with sufficient memory available.
	Camera is not set in picture/video clip taking mode.	Set the camera to the proper mode for recording video clips, or taking photographs.
	Power is off.	Turn the power on.
Camera is in Auto Power off mode.	Turn the power on.	
Cannot take a picture or a video clip when using an SD memory card.	The SD card is locked or write protected.	Remove the SD card from the card slot and slide the lock switch to off.
Picture is blurred when looking through the viewfinder.	Viewfinder is dirty.	Clean the viewfinder with a soft cloth or cotton swab. See the Camera maintenance section.
Part of the picture/ video clip is missing.	Something was blocking the lens when taking the picture.	Keep hands, fingers, etc. away from the lens when taking a picture.
	The picture was not centered correctly in the viewfinder.	Leave space around the subject when centering the picture in the viewfinder.
Camera is not responding during picture capture.	The battery level is low and the camera does not have sufficient power to complete picture capture.	Replace batteries.

SYMPTOM	POSSIBLE CAUSE	POSSIBLE SOLUTION
The shutter button does not work.	The camera is not turned on.	Turn the camera on.
	The camera is processing a picture; the ready LED light is still blinking.	Wait until the light stops blinking before attempting to take another picture.
LCD		
The LCD display is dark.	Protective plastic film still in place on the camera.	Make sure the protective plastic film covering the LCD during shipment, has been removed.
	The LCD brightness level is set too low.	Increase the brightness level on your LCD to meet your personal needs. See p.40 for setting the brightness.
The LCD screen looks milky and or scratched.	Protective plastic film still in place on the camera.	Make sure the protective plastic film covering the LCD during shipment, has been removed.
The LCD is not displaying anything.	LCD is turned off.	Turn the LCD on, by pressing (□).
	The battery level is low.	Replace the batteries.
VIEWING VIDEO CLIPS ON THE COMPUTER (WINDOWS 98/98SE/2000)		
Cannot playback stored video clips on the computer.	Video playback files are missing.	Install Microsoft DirectX 9. (p.49)
INSTALLING SOFTWARE AND DRIVERS		
Camera is not responding during picture download to the PC.	The operating system may not be allocating adequate resources to download the pictures.	Reset the camera by pressing the reset button with a pointed object such as a pen. Reboot the computer.
	The Mini-USB cable is not plugged into the camera.	Check that the Mini-USB cable is plugged into the camera.
	The Mini-USB cable is not plugged into the computer.	Check that the USB cable is plugged into the computer.
	The computer is not powered on.	Turn your computer on.
Cannot transfer pictures to the computer. The New Hardware Wizard cannot locate drivers. (Windows 98/98SE)	The Software is not installed on the computer.	Disconnect the Mini-USB cable from the camera and the computer. Install the camera software and drivers. (p.49)
	Software is not fully or correctly installed on the computer.	Disconnect the Mini-USB cable from the camera and the computer. Uninstall the software: Start-Settings-Control Panel-Add/Remove Programs. Re-install the camera drivers. (See p.49)

SYMPTOM	POSSIBLE CAUSE	POSSIBLE SOLUTION
SD CARDS		
The camera does not recognize your SD Card.	The card may not be SD certified.	Purchase a certified SD card.
	The card may be corrupted. Reformat the card.	Caution: Formatting erases all pictures on the card. p.41
	No card is inserted in the camera.	Insert a card into the card slot. See p.8.
RECHARGEABLE BATTERIES		
A low battery warning appears during initial use of the freshly charged batteries.	The batteries are not placed properly.	Remove and reload the batteries.
Battery life is short.	The batteries haven't reached their maximum capacity.	Fully charge/discharge the batteries via normal operation for three to four cycles

GETTING HELP

You can get help from our troubleshooting section, FAQ on our website or by contacting a customer support representative.

Troubleshooting Section

If you need help with your camera, refer to the Troubleshooting section of this manual on page 61.

Website Customer Support/FAQ

Please visit our customer support website at www.concord-camera.com to view the Frequently Asked Questions (FAQ) by clicking the appropriate camera model picture in the "Camera Support" Section. Most support issues are answered in the FAQ section. You can also E-mail us by clicking the E-mail address link to the customer support center in the "Camera Support" Section.

Customer Support Before You E-mail or Call us

If you have questions concerning the operation of the camera or software installation, you can speak to or email a customer service representative. Please have the following information available:

Camera Information:

Name of camera model
Camera Serial Number
Camera Info in camera (page 38):
FW Version
FW Part Number
Date CD-ROM
Comment

Computer Information:

Operating System
Processor Speed (MHz)
Computer Make and Model
Amount of memory
Exact Error message received
Part Number

For Camera Support please contact:

Toll Free in the US and Canada:

- (866) 522-6372

Web: www.concord-camera.com

For Camera Support via E-mail, please contact us at www.concord-camera.com.

Toll Free in Europe:

UK: 0800-1696482
Spain: 900-973195
Germany: 0800-1800563
Italy: 800-781883
France: 0800-917599

Toll in Europe:

- +31-53-4829779

For ArcSoft Technical Support on Photo Editing Software, please contact:

In the USA and Canada

ArcSoft, Inc.
46601 Fremont Blvd.
Fremont, CA 94538
Tel: (510) 440-9901
Fax: (510) 440-1270
E-mail: support@arcsoft.com

Europe

Unit 14, Shannon Industrial Estate
Shannon, Co. Clare, Ireland
Tel: +353 (0) 61-702087
Fax: +353 (0) 61-702001
E-Mail: europe@arcsoft.com

China

ArcSoft Beijing Co., Ltd.
No. 6 South Capital Gym Road
Beijing New Century Hotel Office
Building, #1060
Beijing 100044, China
Tel: 8610-6849-1368
Fax: 8610-6849-1367
E-Mail: tech@arcsoft.com.cn

Latin America Local calls only

Tel (Brazil): 00817-200-0709
Tel (Chile): 800-202-797
E-Mail: latinsupport@arcsoftsupport.com

Japan

ArcSoft Japan
9F, 1-21-9, Higashi-Gotanda,
Shinagawa-ku,
Tokyo 141-0022, Japan
Tel: +81-3-5795-1392
Fax: +81-3-5795-1397
E-Mail: support@arcsoft.jp

Taiwan

ArcSoft Inc. Taiwan Branch
Tel: +886 (0) 2-2506-9355
Fax: +886 (0) 2-2506-8922
E-Mail: support@arcsoft.com.tw

CAMERA SPECIFICATIONS

Lens	7.23 - 21.7mm (equivalent to 35-105mm in 35mm format), f/2.8 - f/4.7, 6 groups 6 elements all glass with 2 aspherical elements
Aperture	2 steps: f/2.8 and f/5.6 at wide zoom position
Shutter	Electronic, 4s – 1/2000s
Optical Zoom	3x in 11 steps
Digital Zoom	6x
Focus Range	Auto Focus from 60cm to infinity (23.6 in. to infinity), macro from 10 cm to 60 cm (4 in. to 23.6 in.)
Focusing System	5 area multi-area AF, Center spot AF
Image Sensor Type	1/1.8" CCD
Sensor Effective Pixels	4.0 Megapixels
Image Aspect Ratio	4:3
Sensor Color Filter Array	R-G-B
Image Size	2272 x 1704, 2048 x 1536, 1600 x 1200, 1280 x 960, 640 x 480
Image Quality	Fine (4.5:1), Normal (11:1), Economy (17:1)
Sensitivity (ISO setting)	Auto, 100, 200, 400 (user selectable)
Capture Mode	Single Shot, Sport, Continuous Shot, Sport + Continuous Shot
Exposure	Auto
Auto Exposure metering	Spot, Matrix
White Balance	Auto, Sunny, Fluorescent, Tungsten
Scene Selection	Off, Party/Indoor, Beach, Snow, Night Landscape, Sunset, Fireworks, Night portrait.
Picture Effect	Off, B&W, Solarize, Sepia
Exposure Compensation	+/-0, 0.3, 0.7, 1.0, 1.3, 1.7, 2.0 EV
Continuous Shoot	7 frames in 2.3sec with 2MB resolution
Video Clips	AVI format, with audio • 320x240 or 160x120 resolution with 30 fps, approx 50sec/16MB storage.
Self-Timer	10s delay with blinking red LED (7s slow blinking and 3s fast blinking), available for camera and video clip.
Storage Type	Internal Memory and SD card
Internal Storage	16MB Internal Non-Volatile Memory

Storage Capacity**Images Stored on 16MB memory (approx.):**

Image Quality	Image Size				
	4MP (2272 x 1704)	3MP (2048 x 1536)	2MP (1600 x 1200)	1.3MP (1280 x 960)	VGA (640 x 480)
Fine (4.5:1)	14	16	23	33	94
Normal (11:1)	32	37	52	77	200
Economy (17:1)	46	53	81	110	248

Images Stored on 32MB memory (approx.):

Image Quality	Image Size				
	4MP (2272 x 1704)	3MP (2048 x 1536)	2MP (1600 x 1200)	1.3MP (1280 x 960)	VGA (640 x 480)
Fine (4.5:1)	27	31	45	63	188
Normal (11:1)	64	74	105	144	378
Economy (17:1)	93	102	145	202	478

Images Stored on 64MB memory (approx.):

Image Quality	Image Size				
	4MP (2272 x 1704)	3MP (2048 x 1536)	2MP (1600 x 1200)	1.3MP (1280 x 960)	VGA (640 x 480)
Fine (4.5:1)	54	62	93	130	372
Normal	129	147	217	288	774
Economy	186	204	290	404	956

Images Stored on 128MB memory (approx.):

Image Quality	Image Size				
	4MP (2272 x 1704)	3MP (2048 x 1536)	2MP (1600 x 1200)	1.3MP (1280 x 960)	VGA (640 x 480)
Fine (4.5:1)	111	127	181	257	776
Normal	254	300	434	603	1565
Economy	372	378	605	893	1980

Output file format

JPEG compression with EXIF 2.2

Optical Viewfinder

Real image zoom finder with 70-90% coverage

LCD

1.5" TFT LCD, 326(H) x 240(V), 78,240 Pixels

Playback Zoom

2x, 4x, 6x (for 2272x1704 and 2048x1536),
 2x, 4x (for 1600x1200, 1280x960);
 2x (for 640x480)

Flash Mode

Auto, Auto + RER, Flash ON and Flash off.

Flash Range

0.6 to 3.7m (1.97 to 12.14ft) @ISO200 in Wide;
 0.6 to 2.3m (1.97 to 7.55ft) @ISO200 in Tele.

User Interface

All information and menus are displayed on TFT LCD display, Review Image, shows frame counter, flash status, self timer, focus mode, image quality, image size, battery status and memory card.

Multi Language Support

User selectable UI on TFT OSD menu. The languages included are Spanish, Italian, German, English, French, Dutch, Simplified Chinese, Japanese and Portuguese.

Mode Selection	Slide Switch for Camera, Review, Video
Slide Show	Yes
AF Assist Light	Yes
Speaker	Yes
Tripod Socket	Standard 1/4" size
Connectivity	Mini USB and TV/VCR Out
System Connectivity	Mass Storage Driver for Window 98, 98SE, 2000, ME, XP Mass Storage Driver for Mac OS 9.x or above
Time Out	1 minute for LCD. 2 minutes or 3 minutes programmable auto power off for camera.
Power Source	2x AA batteries, can use alkaline, lithium and rechargeable NiMH type (Rechargeable NiMH type Highly Recommended)
Dimensions	100 x 61 x 31.5 mm without protrusions
Weight	150g without batteries and memory card
Accessories	See the separate "Packing Content" sheet.

SAFETY TIPS AND MAINTENANCE

Cleaning the camera body:

1. Please use a soft dry cloth to clean the camera.

Cleaning the lens, viewfinder and LCD:

1. Blow off dirt or dust with a blower or canned air.
2. Gently wipe the lens, viewfinder and/or LCD with a micro-fiber cloth.
3. To remove dirt or residue, moisten the cloth with lens cleaning fluid and gently wipe the lens, viewfinder and/or LCD.

CAUTION: Do not apply the fluid directly onto the lens, viewfinder or LCD.

Cleaning the battery contacts:

As a matter of routine operation and handling, should any debris or foreign contaminant deposit itself on the battery contacts in the camera and/or on the batteries, follow steps below to clean the battery contacts to ensure proper electrical operation:

1. Wet the tip of a cotton bud/swab with rubbing alcohol and squeeze the excess alcohol from the bud/swab.
2. Wipe the battery contacts inside the camera battery compartment and both ends of the batteries lightly with the damp bud.
3. Allow the contacts to dry before placing batteries in the camera.

Caution:

- 1) Do not press hard during cleaning, as this will cause damage to the battery contacts.
- 2) Do not use water to clean the contacts, as this will increase the chance of oxidation.
- 3) Do not use Acetone or Nail Polish remover to clean the contacts as this may adversely affect camera operation.

SAFETY TIPS

Precautions for the camera:

- Do not attempt to modify this camera in any way. This may cause a fire, electric shock or severe damage to the camera.
- Do not use the flash in close proximity to people or animals.
- When taking photographs, never point the lens of the camera directly into very strong light.
- Please do not use this product in close proximity to flammable or explosive gases as this could increase the risk of explosion.
- For safety reasons keep this product and accessories out of reach of children or animals to prevent accidents.
- Do not swallow batteries or small camera accessories.
- Keep the camera away from water and other liquids, and never let it get wet. Do not use outdoors when it is raining or snowing.
- Should any form of liquid enter the camera, do not use it. Switch the camera off, and then remove the batteries. Do not continue to use the camera as this may cause a fire or electric shock.
- Do not insert or drop metallic or inflammable foreign objects into the camera through access points e.g. card slot and battery chamber. This may cause a fire or electric shock.
- Do not operate this camera with wet hands. This could pose a risk of electric shock.
- Under the environment with electrostatic discharge, the camera may malfunction and require the user to reset the camera.
- Under the environment with electrical fast transients (EFT), the camera may lose function and require user to reset the camera.
- Shielded cables must be used with this unit to ensure compliance with the Class B FCC limits.
- Please avoid using the camera in high or low temperature. Operation temperature range 32°F - 104°F (0°C - 40°C).
- It is normal that the temperature of the camera body rises after being in use for a long period.
- Do not leave this camera in places subject to extremely high temperatures, such as in a sealed vehicle, under direct sunlight, or in other places with extreme variances in temperature. Exposure to extreme temperatures may adversely affect the camera's internal components and could cause a fire.
- Always use the camera and its accessories in a well-ventilated area.
- Allowing dust to accumulate in the camera over a long period of time is hazardous and in extreme circumstances may cause a fire. It is best to clean your camera prior to seasonal periods of high humidity.

Precautions for batteries:

- Use 2x AA batteries only.
- Dispose of the batteries in a manner that complies with applicable laws.
- Leakage, overheating, or burst batteries could result in fire or injury.
- Do not short circuit, heat or dispose of batteries in fire.
- Do not use old batteries with new ones, or mix brands of batteries.
- Ensure the batteries are positioned correctly with regard to polarity (+/-).
- Batteries may lose power if kept inside the camera for a long time without using. Please remove the batteries while the camera is not in use.
- Do not use manganese batteries as they cannot supply sufficient power to support the camera's operations. Batteries may not work normally under 32°F (0°C).

Precautions for SD Memory Cards:

- In the event of malfunction or damage, it is possible that data may be lost. Concord Camera is not responsible in any way for such data loss.
- Do not touch the terminals with hands or metal objects.
- Keep dust, water and foreign objects away from the terminal section.
- Avoid heat, liquid and direct sunlight when using and when storing.
- Do not open the battery/card cover or remove the SD Memory Card while data is being read or written.
- Do not dismantle or modify.
- The recorded data may be lost if the card is affected by strong static electricity, electrical shock, during card

repair or malfunction.

- When using SD Memory Cards do not change the attributes (read-only, etc.) of the files (pictures (JPEG) or video clips (AVI) on the card. Doing so may prevent the camera from working properly when deleting, etc.
- Do not change the file names or the directory name of the pictures or video clips using a computer or save files other than pictures or video clips taken by this camera onto the SD memory card. Pictures or video clips that have been edited or added to the SD memory card with the computer may not play back and it may cause the camera to malfunction.
- The SD Memory Card includes a write-protect switch. Sliding this switch downward prevents data from being written to the card and pictures and video clips saved on the card are protected.
- Please note that pictures and video clips cannot be taken or deleted when the write-protect switch is on.
- When using a large-capacity card, writing, reading and deleting may take some time.
- Do not store the card in places with high humidity, dusty places or where static electricity or electromagnetic fields are likely to occur.
Images stored in the memory card may be ruined or damaged if you turn off the camera while it is in process of reading, writing or formatting etc.
- SD cards are delicate electronic devices. Please do not bend or drop them
- Please do not place the SD card in or near to an environment of strong electronic or magnetic fields such as loud speakers or TV receivers.
- Please keep the SD card in its bag or case when not in use.
- It's normal that the SD card is warm after use.
- Please make sure you switch off the camera before you remove the SD card.
- Do not open the battery/memory card door or remove the SD Memory Card while the camera is reading, writing or formatting the card.

REGULATOR INFORMATION

FCC INFORMATION

FCC WARNING: This equipment meets the limits for a Class B digital device, pursuant to Part 15 of FCC rules. Only the cable supplied with the camera should be used. Operation with other cables is likely to result in interference to radio and TV reception and could void the user's authorization to operate this equipment. This device complies with Part 15 of the FCC Rules. Operation is subject to the following two conditions:

- This device may not cause harmful interference.
- This device must accept any interference received, including interference that may cause undesired operation.

*Tested to comply
with FCC standards
for HOME OR OFFICE USE*

Changes or modifications not expressly approved by the manufacturer may void the user's authority to operate this equipment.

USER INFORMATION

NOTE: This equipment has been tested and found to comply with the limits for a class B digital device, pursuant to Part 15 of the FCC Rules. These limits are designed to provide reasonable protection against harmful interference in a residential installation. This equipment generates, uses and can radiate radio frequency energy and, if not installed and used in accordance with the instructions, may cause harmful interference to radio communications. However, there is no guarantee that interference will not occur in a particular installation.

If this equipment does cause harmful interference to radio or television reception, which can be determined by turning the equipment on and off, the user is encouraged to try to correct the interference by one or more of the following measures:

- Reorient or relocate the receiving antenna.
- Increase the separation between the equipment and receiver.
- Connect the equipment into an outlet on a circuit different from that to which the receiver is connected.
- Consult the dealer or an experienced radio/TV technician for help.

VCCI INFORMATION

This is a Class B product, to be used in a domestic environment, based on the Technical Requirement of the Voluntary Control Council for Interference (VCCI) from Information Technology Equipment. If this is used near a radio or television receiver in a domestic environment, it may cause radio interference. Please install and use the equipment according to this instruction manual.

 - This product is in conformity with Directive 89/336/EEC.